



IPC-HERMES-9852

The global standard for "M2M" in SMT assembly

IPC-HERMES-9852

IPC-HERMES-9852

The Global Standard for Machine-to-Machine Communication in SMT Assembly

Version 1.2.1

Contributing companies:

Achat Engineering GmbH	MIRTEC
ASM AS GmbH	MYCRONIC
ASYS Automatisierungssysteme GmbH	Nordson ASYMTEK & MATRIX
BESI	Nutek Europe B.V.
BTU	OMRON Corporation
cts	OSAI
CTI Systems	PARMI
CYBEROPTICS	Pemtron
ECD	Rehm Thermal Systems GmbH
ERSA GmbH	RG Elektrotechnologie
EUNIL	SAKI Corp
eXelsius	SEHO
FLEXLINK	SEICA Automation
GKG	Shenzhen Rejoint Automachine Equip. Co. Ltd.
GÖPEL electronic GmbH	SICK
HANWHA	SMT Thermal Discoveries
Heller Industries	Solderstar
IPTE	SONIC Technology
ITW EAE	SPEA S.p.A.
JAPAN UNIX Co. Ltd.	Test Research, Inc. (TRI)
Keysight	UIC
KIC	VISCOM AG
KOH YOUNG Technology Inc.	ViTrox
Kulicke & Soffa	YJ Link Co., Ltd.
MAGIC RAY Technology	YXLON



Contents:

1	Scope	4
2	Technical Concept	5
2.1	Prerequisites	5
2.2	Board IDs	5
2.3	Machine-to-Machine Communication (Horizontal Channel)	5
2.3.1	Topology	5
2.3.2	Connecting, Handshake and Detection of Connection Loss	6
2.3.3	Normal Operation	8
2.3.4	Transport Error Handling	9
	Scenario U1a	10
	Scenario U1b	11
	Scenario U2	12
	Scenario U3	13
	Scenario D1	14
	Scenario D2	15
	Scenario D3	16
2.3.5	Handling of BoardForecast	17
	Scenario 1	17
	Scenario 1 (Error Handling)	18
	Scenario 2	19
2.3.6	Protocol States and Protocol error Handling	20
2.4	Remote Configuration	21
2.4.1	Topology	21
2.4.2	Remote configuration	21
2.5	Communication with Supervisory System (Vertical Channel)	21
2.5.1	Topology	21
2.5.2	Connecting, Handshake and Detection of Connection Loss	22
2.5.3	Protocol States and Protocol Error Handling	24
3	Message Definition	25
3.1	Message Format	25
3.2	Root Element	25
3.3	CheckAlive	26
3.4	ServiceDescription	26
3.5	Notification	28
3.6	BoardAvailable	28
3.7	RevokeBoardAvailable	30



3.8	MachineReady	31
3.9	RevokeMachineReady	32
3.10	StartTransport.....	32
3.11	StopTransport.....	32
3.12	TransportFinished.....	33
3.13	BoardForecast	33
3.14	QueryBoardInfo	35
3.15	SendBoardInfo.....	36
3.16	SetConfiguration.....	38
3.17	GetConfiguration	40
3.18	CurrentConfiguration	40
3.19	SupervisoryServiceDescription.....	41
3.20	BoardArrived.....	41
3.21	BoardDeparted	45
3.22	QueryWorkOrderInfo	48
3.23	SendWorkOrderInfo.....	49
4	Appendix.....	52
4.1	Special Scenarios.....	52
4.1.1	Board Tracking When Board Is Torn Out From the Line	52
4.1.2	Board Tracking When Board Is Temporarily Removed From the Line	53
4.1.3	Board Tracking When Board was Transferred Without Data	54
4.2	Glossary / Abbreviations	55
4.3	References	55
4.4	History	56



1 Scope

The aim of this specification is to create a state-of-the-art communication protocol for surface-mount technology (SMT) production lines. Therefore, this new communication protocol has to cope with the following:

- Replace the electrical SMEMA interface as specified in [IPC_SMEMA_9851]
- Extend the interface to communicate (including):
 - Unique identifiers (IDs) for the handled printed boards
 - Equipment identifiers of the first machine noticing a printed board
 - Barcodes
 - Conveyor speed
 - Product type specific information (including):
 - Product type identifier
 - Length
 - Width
 - Thickness

With respect to version numbers IPC-HERMES-9852 adheres to the rules of Semantic Versioning 2.0.0 [SemVer_2.0.0].

Hints on naming:

- Wherever a feature is described by the word "**shall**", it is mandatory.
- The word "machine" is used for any equipment which can be found in a SMT production line (e.g., printers, placement machines, ovens, automatic optical inspections (AOIs), transport modules, shuttles, stackers, etc.).
- The term "printed board" may also refer to carriers transporting printed boards.
- The word "Hermes" is used as abbreviation for "IPC-HERMES-9852".
- "The Hermes Standard" and IPC-HERMES-9852 are synonyms for the standard specified in this document and might be used interchangeably.



2 Technical Concept

2.1 Prerequisites

This specification is based on the prerequisite, that any application implementing this protocol has to provide connectivity based on Internet Protocol (IP) [IETF_RFC_791] / [IETF_RFC_2460] via Transmission Control Protocol (TCP) [IETF_RFC_793] (International Organization for Standardization / Open System Interconnection (ISO / OSI) model [ISO_7498-1] layer 3) to the adjacent machines and for communication with supervisory systems.

2.2 Board IDs

Board individuals are identified by board IDs. These must be globally unique identifiers (GUIDs) according to [ITU-T_REC_X.667] (e.g., 123e4567-e89b-12d3-a456-426655440000). They are generated by the first machine in a consecutive row of machines implementing the Hermes protocol. The board ID is passed from machine to machine. If a machine in a line does not implement the Hermes protocol, the board ID is lost and a new one will be generated by the next machine implementing Hermes. This is shown in Figure 1.

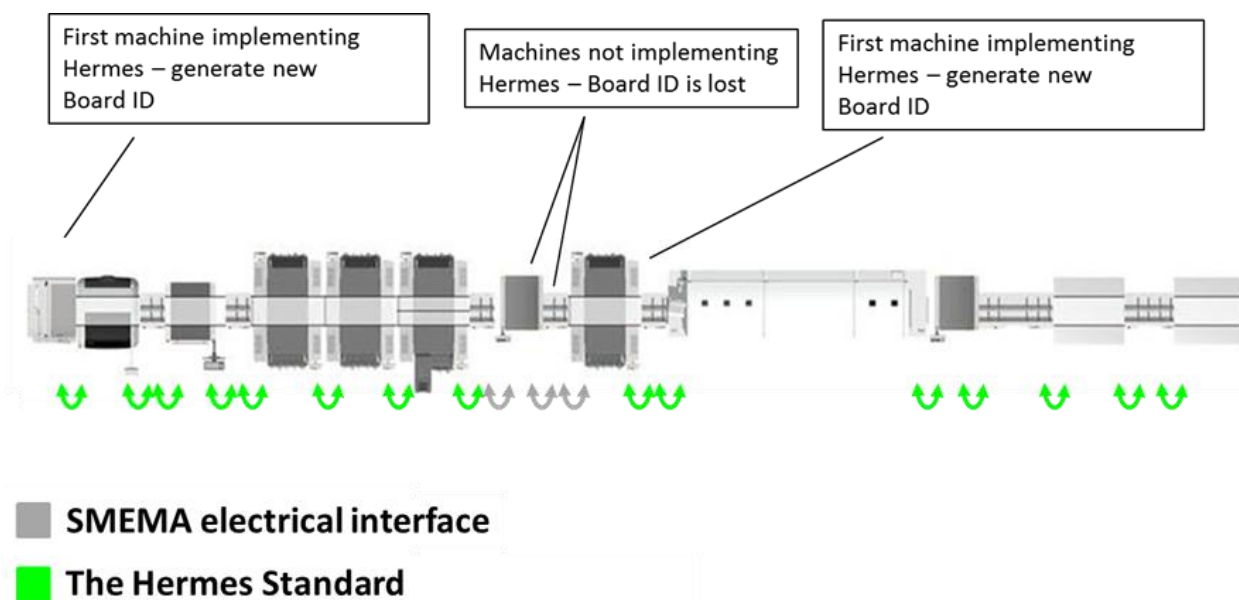

Figure 1 Generation of Board IDs

2.3 Machine-to-Machine Communication (Horizontal Channel)

2.3.1 Topology

Any machine in a line offers one TCP server per lane on its downstream side. Further servers per lane might also be necessary (e.g., if reverse transportation is supported). The TCP port number is not specified but can be configured by the user. The recommended port numbers are 50100 plus lane identifier (ID) with lanes being



enumerated looking downstream from right to left beginning with 1 (i.e., for the left lane of a dual lane machine, the upstream machine server accepts connections on port 50102). For every further server plus 10 is recommended to be added to the port number.

The downstream machine opens one connection for every lane and every transportation interface on its upstream side to the upstream machine(s). So every printed board handover point corresponds to one TCP connection per exchange direction as shown in Figure 2.

Figure 3 explains the applied wording from the point-of-view of a machine.

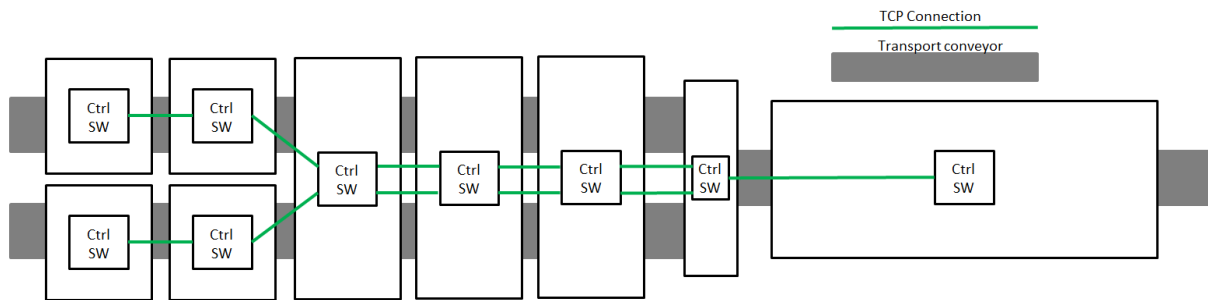

Figure 2 TCP Connections in a Line

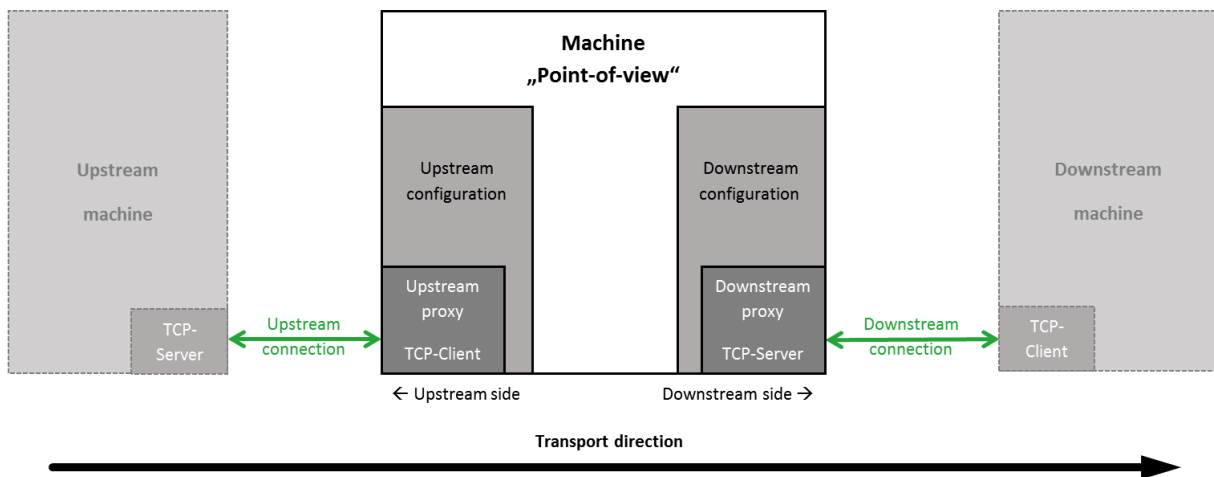

Figure 3 Upstream and Downstream from the Perspective of the Machine

2.3.2 Connecting, Handshake and Detection of Connection Loss

After booting, the downstream machine starts cyclic connection attempts to the configured upstream machines. When a connection is established, the downstream machine starts sending a ServiceDescription message whereupon the upstream machine answers with its own ServiceDescription. This ServiceDescription message contains the lane ID and interface ID (optional) of the sending machine related to this TCP connection. It also contains the implemented version and a list of all optional features and additional features of a higher version



which are implemented by the machine. The features of the Hermes specification version 1.0 have to be supported by any implementation. See Figure 4.

If a downstream machine is already connected to the lane and the transportation interface, this connection will be retained. A Notification message **shall** be sent to the new connection before it is closed.

After exchanging the handshake messages, both machines may begin to send BoardAvailable / MachineReady messages (see 2.3.3).

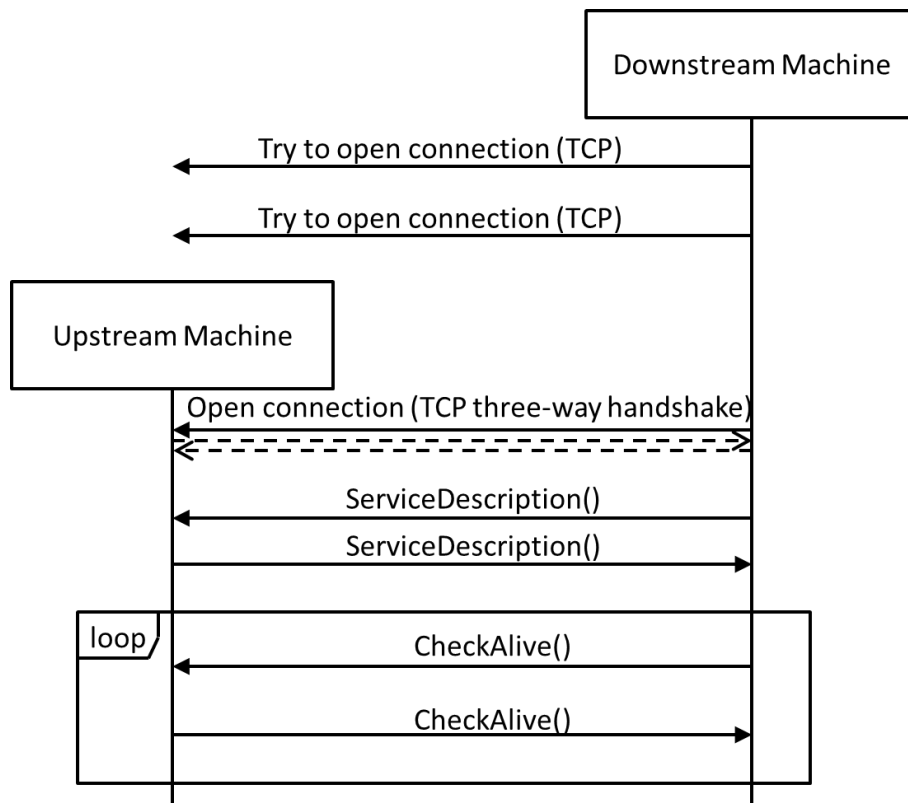

Figure 4 Connection, Handshake and Connection Loss Detection on Horizontal Channel

The connections are kept open all the time. As TCP by itself does not detect connection losses (“half-open connections” caused by, for example, process / computer crash, unplugged network cables, etc.) both sides of a connection have to send cyclic CheckAlive messages. Those messages do not have to be answered by the remote side – the TCP stack will detect a connection loss when trying to send the packet. If the server detects a connection loss, it ends the connection and waits for a new connection by the client. If the client detects a connection loss, it ends the connection and restarts with cyclic connection attempts.

As not all TCP stacks correctly recognize the loss of connection when sending messages it is possible to extend the implementation of this functionality to an exchange of CheckAlive messages. Machines which have implemented this function have the tag FeatureCheckAliveResponse in the ServiceDescription.

The exchange of CheckAlive messages then works like shown in Figure 5.



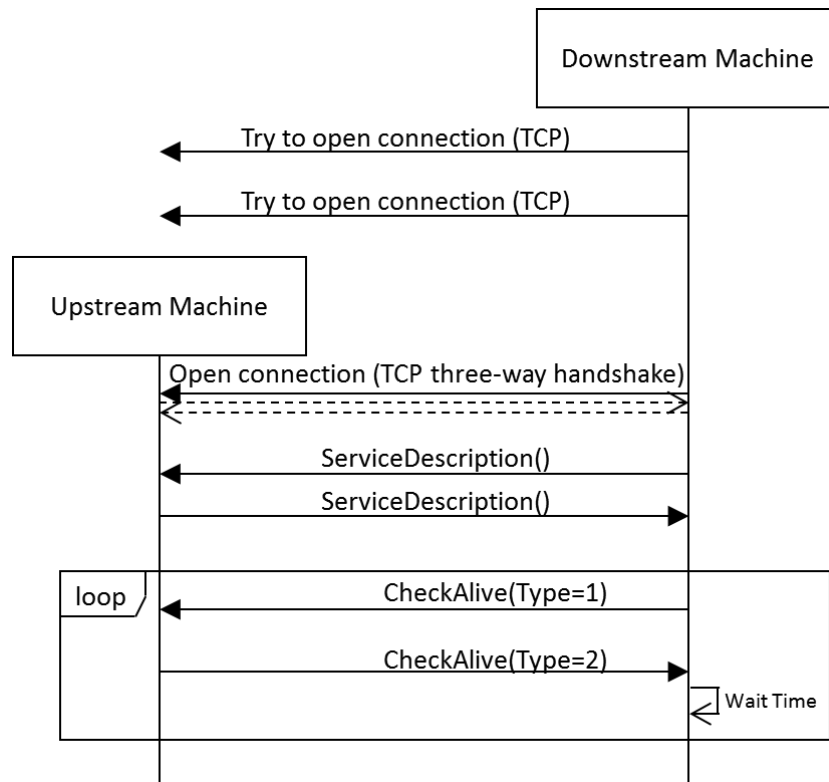

Figure 5 Example for Connection Loss Detection with FeatureCheckAliveResponse on Horizontal Channel

One of the machines (in Figure 5, the downstream machine but it could be also the upstream machine) sends a (ping) CheckAlive message, that is a CheckAlive message with the attribute Type set to 1. The peer machine then responds immediately with a (pong) CheckAlive message, that is a CheckAlive message with the attribute Type set to 2 and the Id matching the Id of the (ping) CheckAlive message. A missing response (It is recommended to wait for 3 seconds.) indicates a connection loss.

2.3.3 Normal Operation

When an upstream machine has a printed board available for handover, it sends a BoardAvailable message while a downstream machine ready to accept a printed board sends a MachineReady message. The naming of these messages is inspired by the electrical SMEMA interface. However, the messages do not represent the state of a machine's interface directly but are events for initiating a printed board handover.



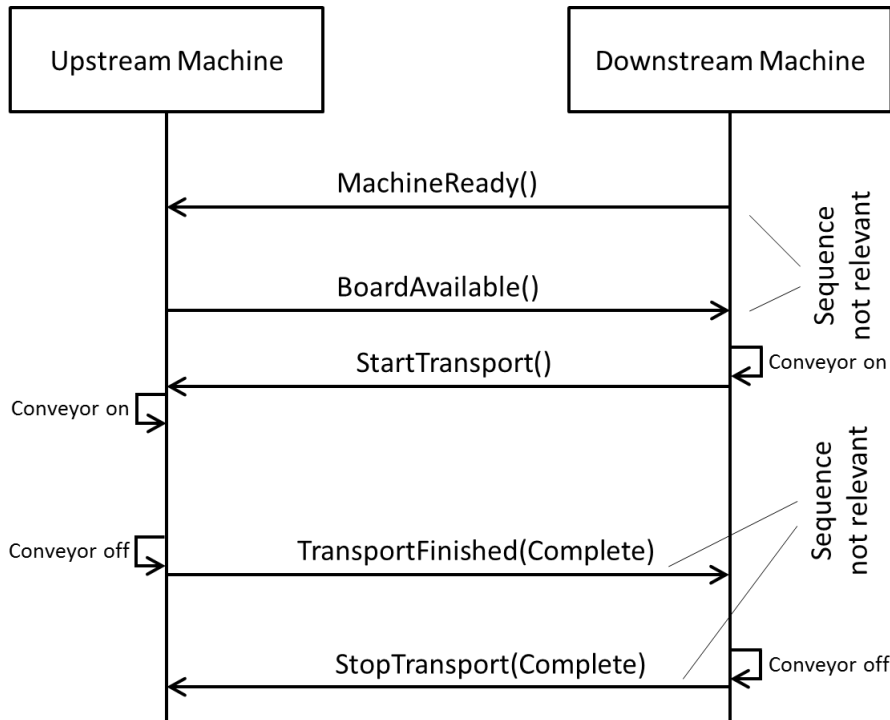

Figure 6 Communication Sequence for Board Transport

When both machines have indicated their readiness to handover the printed board, the downstream machine initiates the transfer by switching on its conveyor and sending the StartTransport message. Upon receiving this message, the upstream machine switches on its conveyor and the printed board moves into the downstream machine.

When the upstream machine is able to state that the printed board has fully left the machine, it sends the TransportFinished message. When the downstream machine has full control of the board, it sends the StopTransport message. The handover of a printed board is finished and is ready to start over.

If the upstream machine receives a StopTransport message and has not sent the TransportFinished message yet, it has to stop its conveyor and send the TransportFinished message.

The MachineReady message does not trigger an action on one of the machines directly. However it still is necessary to realize machines such as shuttles which have to react to the availability of their downstream machines.

See Figure 6.

2.3.4 Transport Error Handling

To keep this protocol hardware independent, the handling of transport errors is described based on a very simple model of the board handover. The handover process is structured into the three phases:

- 1) NotStarted: The board is fully inside the upstream machine.
- 2) Incomplete: The board is partly inside both machines.
- 3) Complete: The board is fully inside the downstream machine.

Any state or event which prevents one or both machines from handing over a printed board is interpreted as an error. An error may be detected by any of the machines in any of the three handover phases. It is up to the



application how to detect the current handover phase, how to detect errors and how to solve them eventually (e.g., sensors, model based prediction, timeouts, user interaction, etc.).

The following sequence charts give an overview of the communication within this protocol depending on the machine which detects the error and the phase in which it is detected. The point in the sequence where the error is detected is marked by the following symbol: ●→^{Stop}

Scenario U1a

- Error detected by the upstream machine
- Printed board fully inside the upstream machine
- Error detected before StartTransport has been received

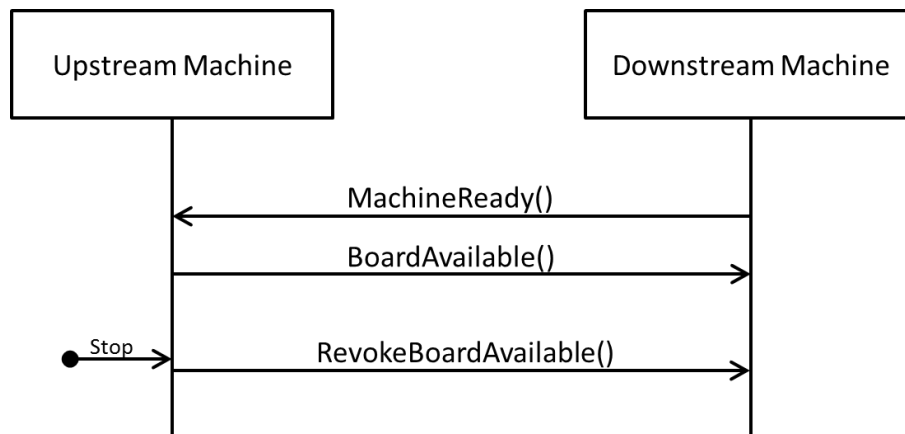

Figure 7 Communication Sequence in Scenario U1a

Error detection: The error is detected before any transport started.

Reaction on upstream machine: The upstream machine sends a RevokeBoardAvailable message.

Reaction on downstream machine: None.

Resolution: After the error is solved, the regular transport sequence can start from the beginning.

See Figure 7.

Scenario U1b

- Error detected by the upstream machine
- Printed board fully inside the upstream machine
- Error detected after StartTransport has been received

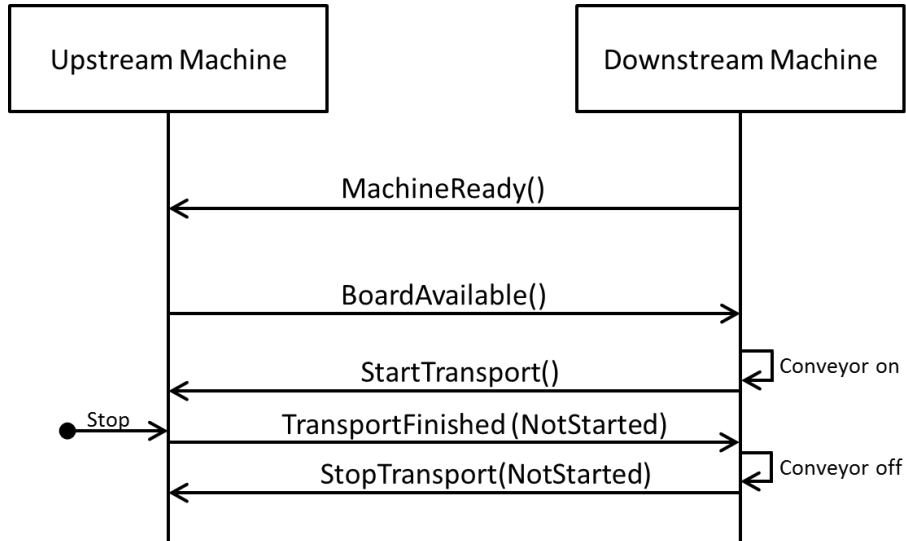

Figure 8 Communication Sequence in Scenario U1b

Error detection: The error is detected after the downstream machine started its conveyor and has sent the StartTransport message.

Reaction on upstream machine: The upstream machine sends a TransportFinished message indicating that it has not started the transport.

Reaction on downstream machine: Upon the TransportFinished message, the downstream machine stops its conveyor and sends a StopTransport message indicating that no transport has started.

Resolution: After the error is solved, the regular transport sequence can start from the beginning.

See Figure 8.



Scenario U2

- Error detected by the upstream machine
- Printed board partly inside both machines

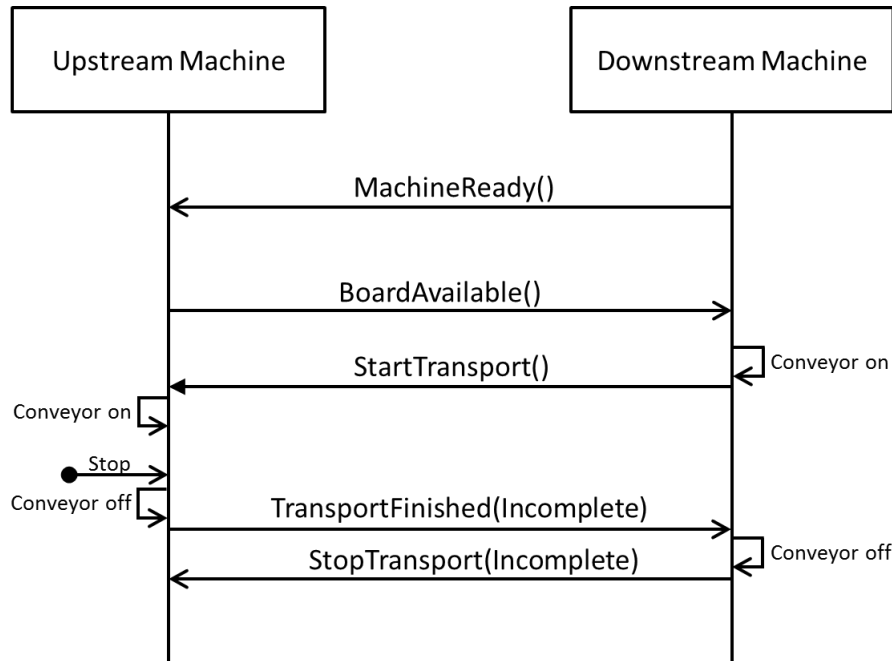

Figure 9 Communication Sequence in Scenario U2

Error detection: The error is detected after both machines started their conveyors. The upstream machine assumes that the printed board may have partly entered the downstream machine.

Reaction on upstream machine: The upstream machine sends a TransportFinished message indicating that the printed board might be located between the machines.

Reaction on downstream machine: Upon the TransportFinished message, the downstream machine stops its conveyor and sends a StopTransport message indicating the state of the printed board handover. Note that in Figure 9 the StopTransport message is represented with parameter "Incomplete". However in this scenario, the downstream machine could send any of the allowed transport states.

Resolution: After the error is solved, the regular transport sequence can start from the beginning. The regular transport message sequence also applies to a printed board located between the two machines.

See Figure 9.



Scenario U3

- Error detected by the upstream machine
- Printed board fully inside the downstream machine

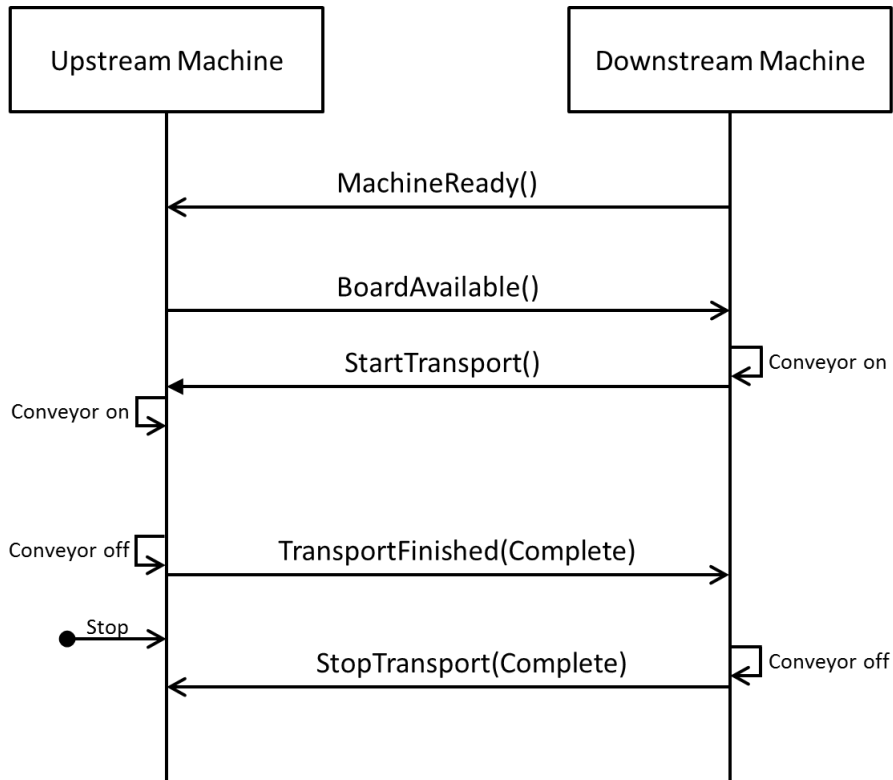

Figure 10 Communication Sequence in Scenario U3

Error detection: The error is detected after the printed board is fully inside the downstream machine.

Reaction on upstream machine: None. Although the machine detected an error, it is irrelevant for the handover process.

Reaction on downstream machine: None. The downstream machine is not aware of any error.

Resolution: This scenario is irrelevant for the Hermes protocol. It is just listed for completeness.

See Figure 10.



Scenario D1

- Error detected by the downstream machine
- Printed board fully inside the upstream machine
- Error detected before StartTransport has been sent

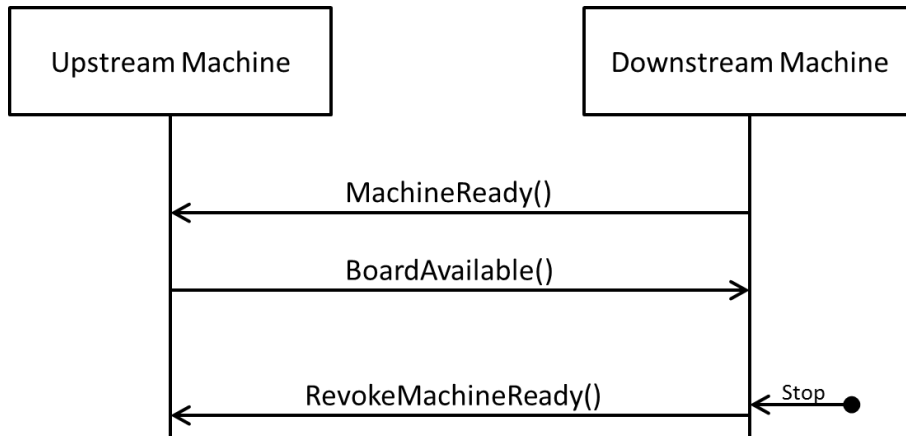

Figure 11 Communication Sequence in Scenario D1

Error detection: The error is detected before any transport started.

Reaction on upstream machine: None.

Reaction on downstream machine: The downstream machine sends a RevokeMachineReady message.

Resolution: After the error is solved, the regular transport sequence can start from the beginning.

See Figure 11.



Scenario D2

- Error detected by the downstream machine
- Printed board partly inside both machines

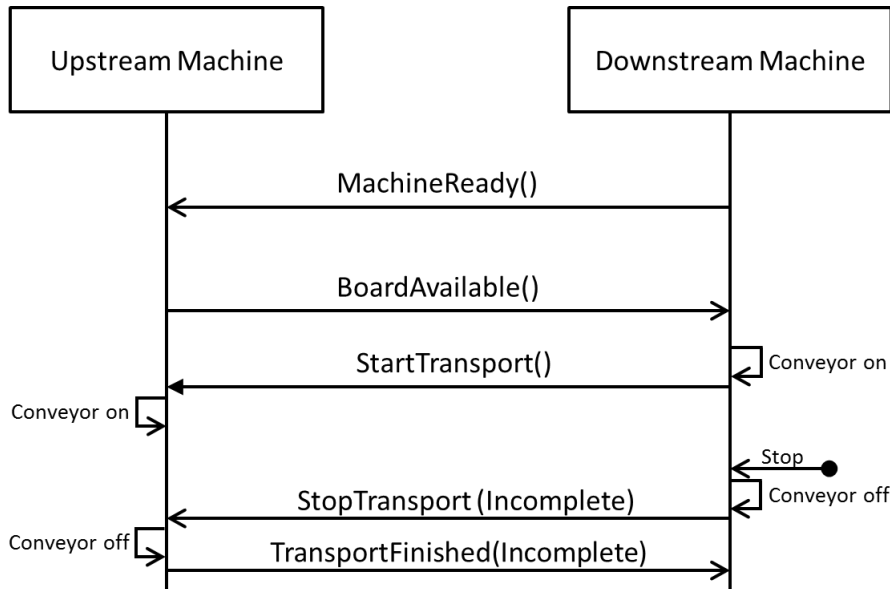

Figure 12 Communication Sequence in Scenario D2

Error detection: The error is detected after both machines started their conveyors. The downstream machine assumes that the Printed board may already has entered its conveyor.

Reaction on upstream machine: Upon the StopTransport message from the downstream machine, the upstream machine stops its conveyor and sends a TransportFinished message indicating the state of the printed board handover. Note that in Figure 12 the TransportFinished message is represented with parameter "Incomplete". However in this scenario, the upstream machine could send any of the allowed transport states.

Reaction on downstream machine: The downstream machine stops its conveyor and notifies the upstream machine of the error by sending a StopTransport message indicating an incomplete printed board handover.

Resolution: After the error is solved, the regular transport sequence can start from the beginning. The regular transport message sequence also applies for a printed board located between the two machines.

See Figure 12.



Scenario D3

- Error detected by the downstream machine
- printed fully inside the downstream machine

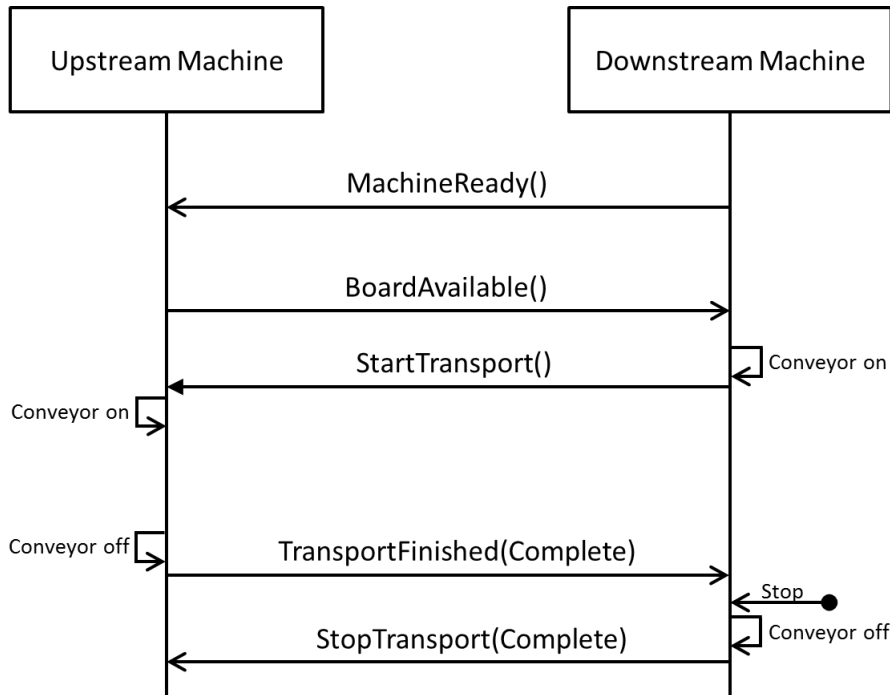

Figure 13 Communication Sequence in Scenario D3

Error detection: The error is detected after the printed board is fully inside the downstream machine.

Reaction on upstream machine: None. The upstream machine is not aware of any error.

Reaction on downstream machine: None (at least in the scope of this protocol).

Resolution: This scenario is irrelevant for the Hermes protocol. As transport sequences are always initiated by the downstream machine sending StartTransport, troubleshooting (possibly including running the conveyor of the downstream machine) can be executed independently from the upstream machine.

See Figure 13.



2.3.5 Handling of BoardForecast

Among others, the BoardForecast may be used in following scenarios:

- 1) Anticipating a product change without a board (i.e., because upstream machine does not have stoppers / conveyor that can be stopped).
- 2) Sending an estimated time to downstream machine until a board will be available (i.e., to allow downstream machine to choose between several upstream machines to get next available board).

Scenario 1

Upstream machine is processing a changeover (new product type) and wants to ensure that the downstream machine is simultaneously also processing a changeover. Upstream machine also needs to check that this actually happens. It sends a BoardForecast with a (forecast-)ID, to which the downstream machine at some point must respond with a MachineReady with the same ID. Upon receiving this MachineReady, the upstream machine can assume that the product change was successful. See Figure 14.

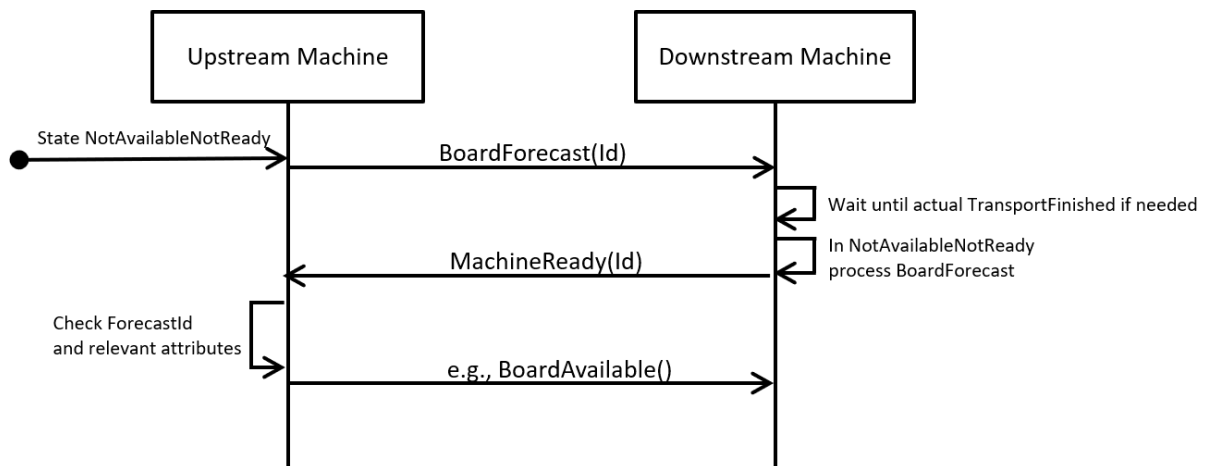

Figure 14 Example of Communication Sequence for BoardForecast

Note: If starting the BoardForecast handling in the state MachineReady, the downstream machine must send a RevokeMachineReady message. See Figure 15.



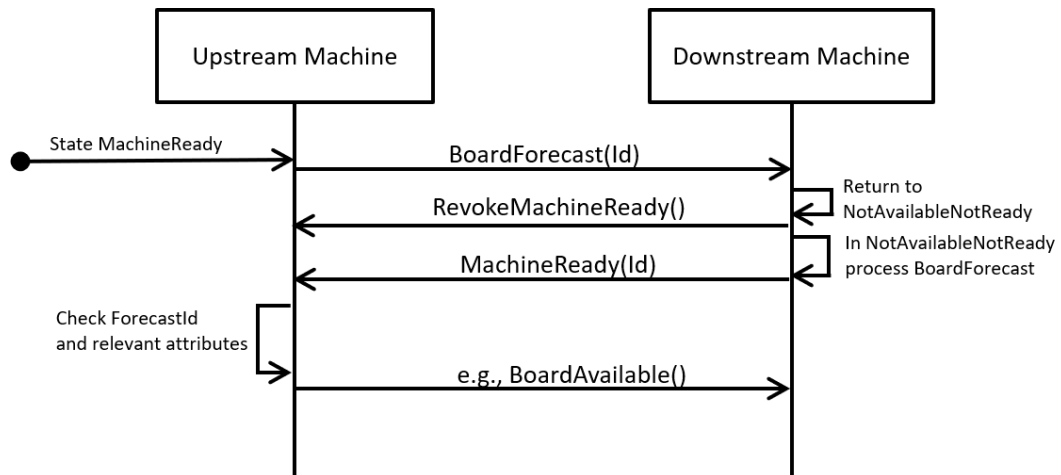

Figure 15 Example of Communication Sequence for BoardForecast with RevokeMachineReady

If several BoardForecast messages (i.e., with different ProductTypeld) are sent in a short delay, the downstream machine may process only the last BoardForecast message. See **Figure 16**.

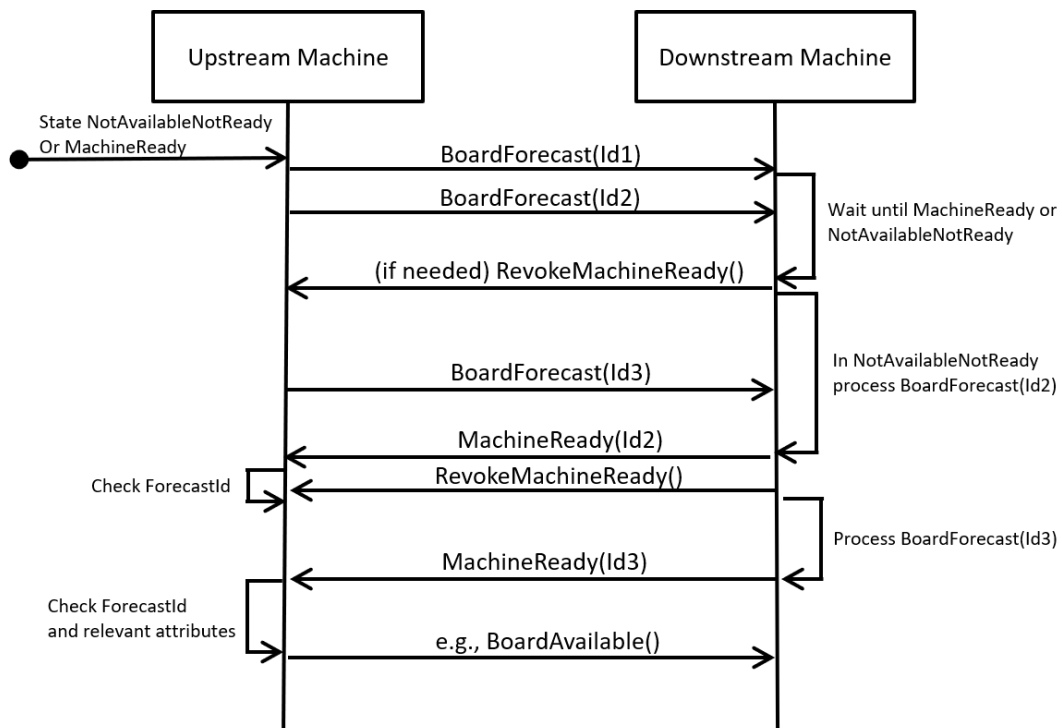

Figure 16 Example of Communication Sequence with Several BoardForecast

Scenario 1 (Error Handling)

If the downstream machine cannot accept the product exchange (i.e., unknown ProductId or width is physically impossible in machine) it will respond after a RevokeMachineReady with a notification of type



“BoardForecastError”. The upstream machine must then do some error handling (i.e., ask operator if machine should retry the BoardForecast or if the operator wants to remove the board). See Figure 17.

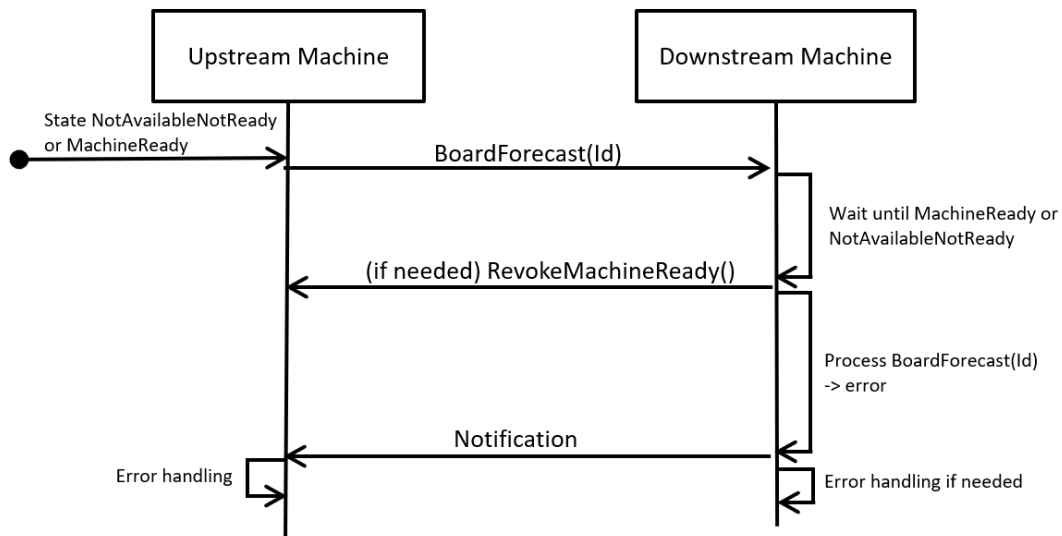

Figure 17 Example of Communication Sequence in Case with Error Handling

Scenario 2

As BoardForecast in that case usually only gives some information to the downstream machine, several BoardForecast may be sent. However, error handling or checking are not needed on the side of the downstream machine. In that scenario ForecastId will not be sent. See Figure 18.

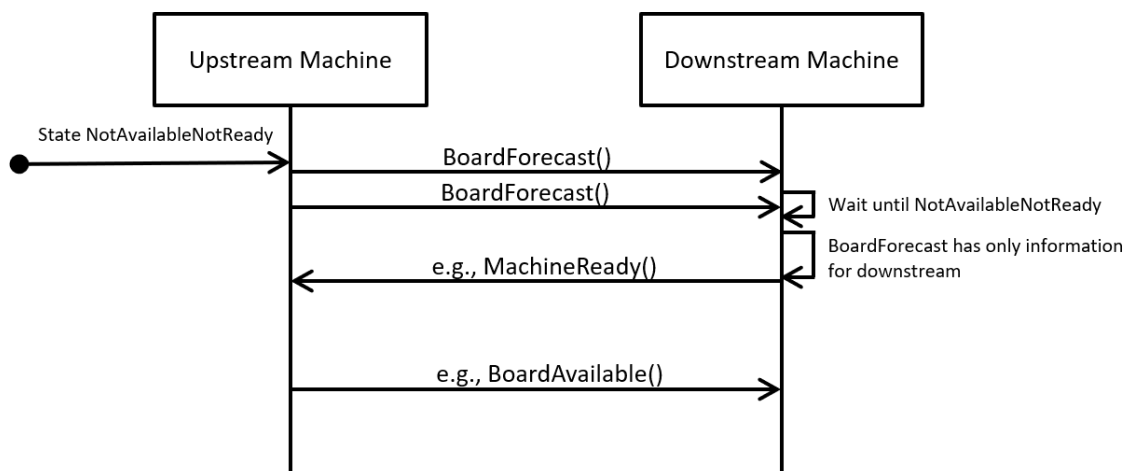

Figure 18 Example of Communication Sequence BoardForecast Without Product Change

Note: The function of BoardForecast is optional. If FeatureBoardForecast is specified in the ServiceDescription, it must be fully supported. Otherwise it can be ignored.



2.3.6 Protocol States and Protocol error Handling

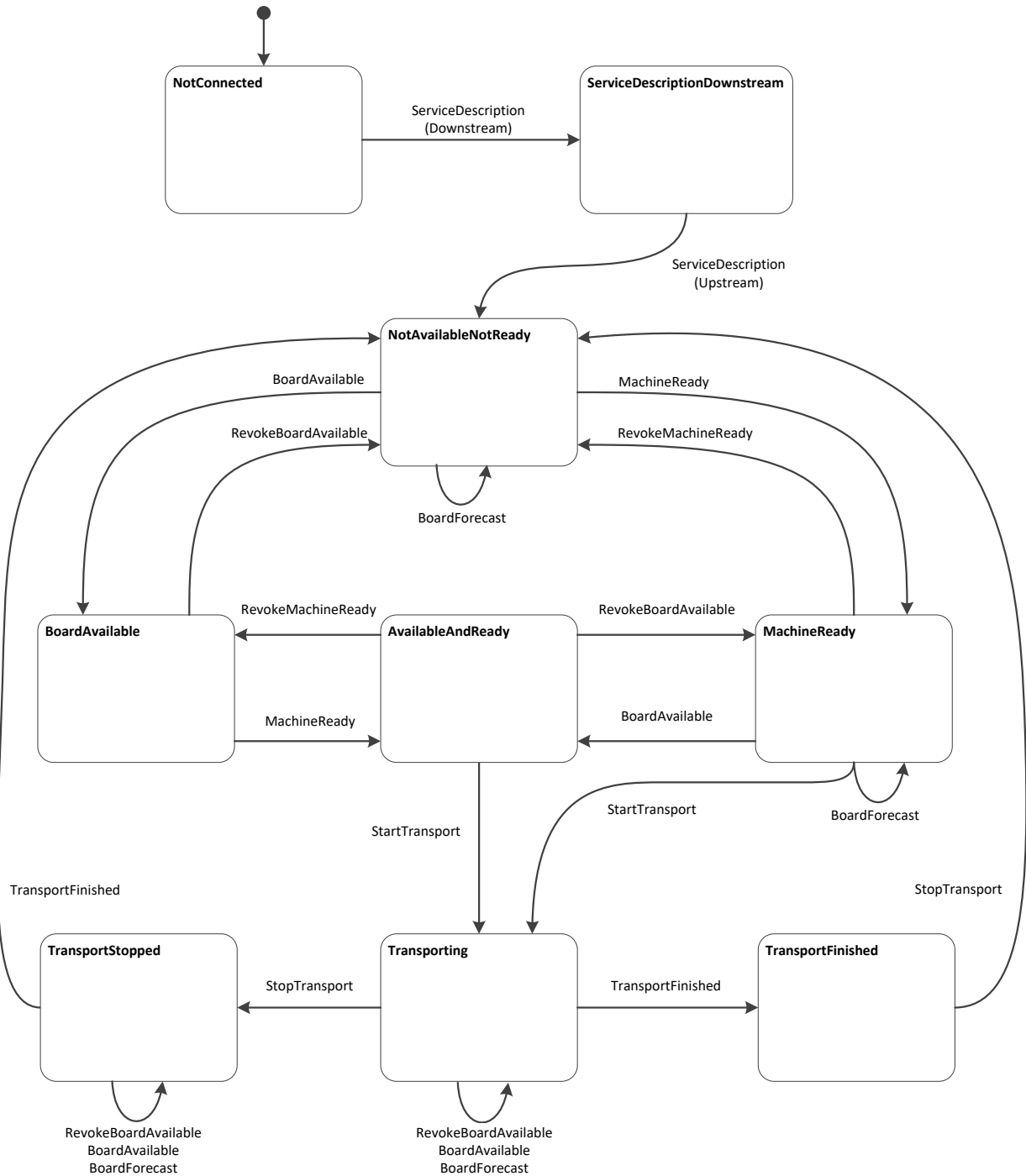

Figure 19 Hermes Interface States on Horizontal Channel

Figure 19 lists all states and transitions of a Hermes interface corresponding to the machine-to-machine (M2M) communication. The state is the comprehensive state of the interface rather than the state of one of the involved machines.



The messages may only be sent if they trigger the corresponding transition shown in the state chart. Any message defined in this standard, except "Notification", "CheckAlive", "QueryBoardInfo" and "SendBoardInfo", which is received not triggering a transition is interpreted as a protocol error (i.e., a MachineReady message when the interface is in the state Transporting). In case of a protocol error, any running transport **shall** be stopped and the connection is terminated. The interface may start over with a new connection. Any unknown message, which is received, **shall** be ignored and discarded to keep upward compatibility.

Note that due to race conditions, a RevokeBoardAvailable message may overlap with a StartTransport message or even a StopTransport message, so this **shall** not be treated as a protocol error (transition from MachineReady to Transporting and self-transitions on Transporting and TransportStopped).

2.4 Remote Configuration

2.4.1 Topology

Although a machine may offer the possibility to configure the Hermes TCP port(s) and the IP address(es) of its upstream machine(s) locally (i.e., via a graphical user interface of the machine controller), every machine implementing this protocol **shall** offer a possibility to configure these properties remote via TCP. Therefore, the machine **shall** offer a TCP server on port 1248 on at least one network adapter where it accepts configuration messages (see 3.16 to 3.18 for detailed information).

The configuration system opens a connection to each required machine. The connection **shall** only be kept open as long as needed and closed by the configuration system.

2.4.2 Remote configuration

A SetConfiguration message **shall** contain the full configuration for all Hermes interfaces of a machine. Any existing configuration is overwritten when a SetConfiguration message is received. Whenever a configuration is not applicable (e.g., bad IP address format), the SetConfiguration message is answered with a Notification message (see 3.5). Every time the configuration is changed, affected open Hermes connections will be reset at the next appropriate moment.

It is possible to read the current configuration through the GetConfiguration message answered by a CurrentConfiguration message. The configuration **shall** be persisted until it is changed.

2.5 Communication with Supervisory System (Vertical Channel)

2.5.1 Topology

Any machine in a line **shall** offer one TCP server on the configured supervisory system port on at least one network adapter where it accepts connections from supervisory systems. The used supervisory system port can be retrieved via GetConfiguration. The connection to the supervisory system is, for example, used to allow the configuration of the Hermes connections to the upstream and downstream machine(s) remotely without relying on the capabilities of the machine user interface.

The supervisory system opens a connection to each required machine. The connection **shall** only be kept open as long as needed and closed by the supervisory system.



Note: It is possible to use the same port for the communication with a supervisory system as for the remote configuration.

2.5.2 Connecting, Handshake and Detection of Connection Loss

Upon demand the supervisory system starts cyclic connection attempts to the required machine. When a connection is established, the supervisory system starts sending a SupervisoryServiceDescription message whereupon the machine answers with its own SupervisoryServiceDescription. This SupervisoryServiceDescription message contains a list of supervisory features which are implemented by the client. See Figure 20.

If a new supervisory system tries to connect and no further connections are supported by the machine, the already established connections will be retained. A Notification message **shall** be sent to the new connection before it is closed.

After exchanging the handshake messages, both communication partners may begin to exchange the messages belonging to supervisory features supported by both communication partners.

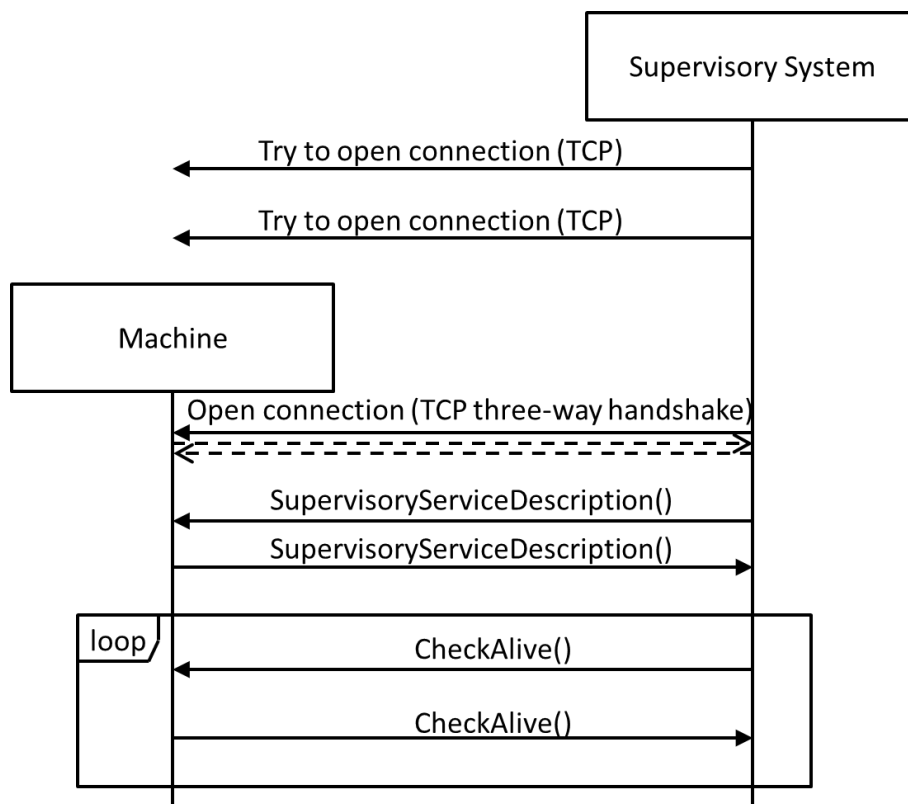

Figure 20 Connection, Handshake and Connection Loss Detection on Vertical Channel

The connections are kept open as long as needed. As TCP by itself does not detect connection losses ("half-open connections" caused by, for example, process / computer crash, unplugged network cable, etc.) both sides of a connection have to send cyclic CheckAlive messages. Those messages do not have to be answered



by the remote side – the TCP stack will detect a connection loss when trying to send the packet. If the server detects a connection loss, it ends the connection and waits for a new connection by the client. If the client detects a connection loss, it ends the connection and restarts with cyclic connection attempts.

As not all TCP stacks recognize correctly the loss of connection when sending messages it is possible to extend the implementation of this functionality to an exchange of CheckAlive messages. Machines which have implemented this function do have the tag FeatureCheckAliveResponse in the SupervisoryServiceDescription. The exchange of CheckAlive messages then works like shown in Figure 21.

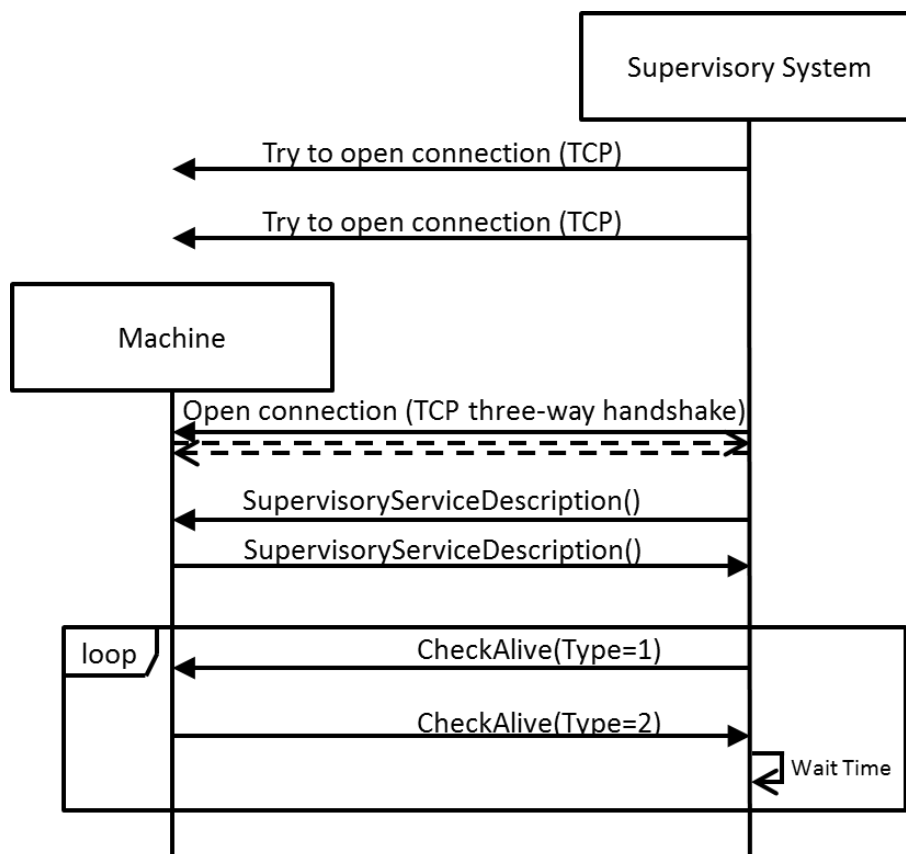

Figure 21 Example for Connection Loss Detection with FeatureCheckAliveResponse on Vertical Channel

One of the communication partners (in Figure 21, the supervisory system but it could be also the machine) sends a (ping) CheckAlive message, that is a CheckAlive message with the attribute Type set to 1. The peer communication partner then responds immediately with a (pong) CheckAlive message, that is a CheckAlive message with the attribute Type set to 2 and the Id matching the Id of the (ping) CheckAlive message. A missing response (It is recommended to wait for 3 seconds.) indicates a connection loss.



2.5.3 Protocol States and Protocol Error Handling

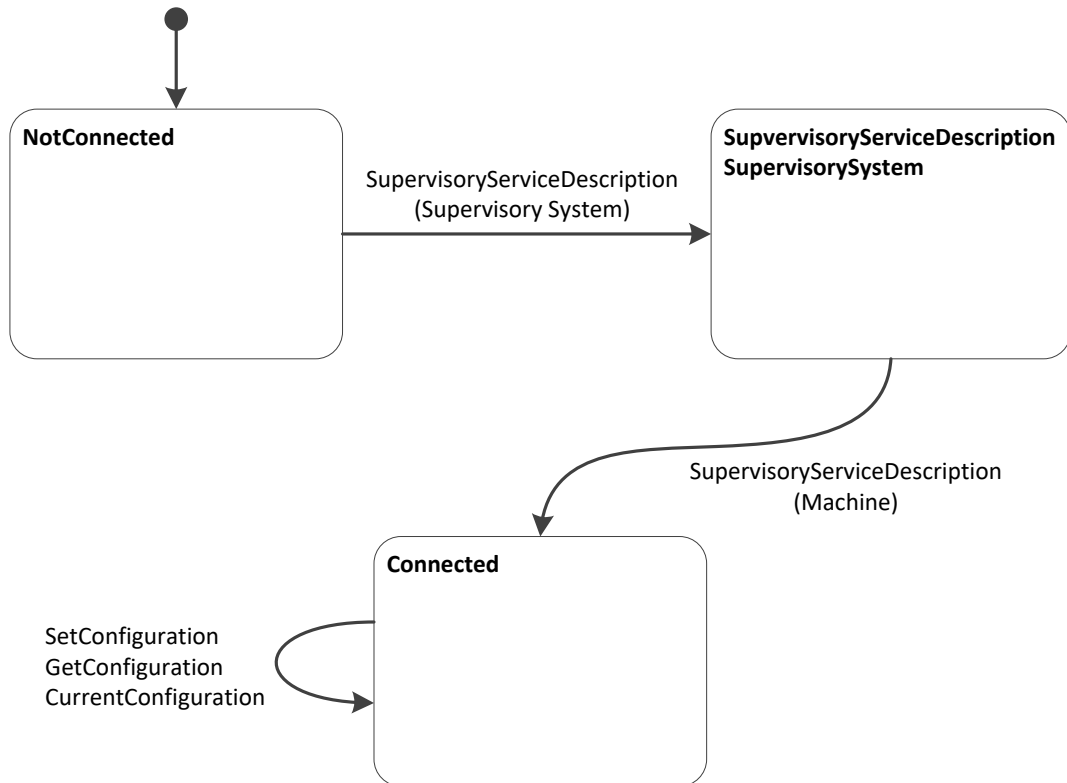

Figure 22 Hermes Interface States on Vertical Channel

Figure 22 lists all states and transitions of a Hermes interface corresponding to the communication with supervisory systems. The state is the comprehensive state of the interface rather than the state of one of the involved communication partners.

The messages may only be sent if they trigger the corresponding transition shown in the state chart. Any message defined in this standard, except “Notification”, “CheckAlive”, “QueryWorkOrderInfo” and “SendWorkOrderInfo”, which is received not triggering a transition is interpreted as a protocol error. In case of a protocol error the connection is terminated. The interface may start over with a new connection. Any unknown message, which is received, **shall** be ignored and discarded to keep upward compatibility.



3 Message Definition

3.1 Message Format

Messages use the Extensible Markup Language (XML) format, where at least version 1.1 of XML **shall** be supported [W3C_XML_1.1].

For character encoding UTF-8 has to be used (No other encoding may be specified in the XML declaration). In the following sections of this document, for a better readable description of the XML data structures, tables are used instead of commonly used schema definitions.

Maximum size for every message is 64 kByte (i.e. 65536 bytes). For every string parameter there is either a fixed or minimum size that must be supported (individual values see tables).

In the tables, XML attributes are marked with the image “” and XML child nodes are marked with the image “”, which in turn may consist of more XML structures.

The representation of data types (e.g., floating point numbers, boolean attributes, etc.) **shall** comply with the W3C XML schema recommendation [W3C_XML_Schema].

To keep upward compatibility, any message or attribute unknown by an implementation can be ignored and discarded.

3.2 Root Element

Every message is enveloped by a common root element with tag <Hermes>. The root element optionally includes a timestamp attribute with the following format (based on the W3C note “Date and Time Formats” [W3C_DATE_TIME]):

```
YYYY-MM-DDThh:mm:ss.s
```

where:

```
YYYY = four-digit year
MM   = two-digit month (01=January, etc.)
DD   = two-digit day of month (01 through 31)
hh   = two digits of hour (00 through 23) (am / pm not allowed)
mm   = two digits of minute (00 through 59)
ss   = two digits of second (00 through 59)
s    = one or more digits representing a decimal fraction of a second
```

The decimal fraction of the second **shall** be given with three digit precision.

The timestamp is optional and intended for diagnostic purposes only.

An example for a CheckAlive message would be:

```
<Hermes Timestamp="2017-07-16T19:20:30.452">
  <CheckAlive />
</Hermes>
```

A machine is not required to emit a precise timestamp, since this attribute is intended mainly for debugging purposes.

Recommendation: Synchronize all machines in a line to a common time source. For machines that do not have an absolute time source, the year should be set to “0000”. At any rate, the timestamp should be monotonic.



3.3 CheckAlive

The CheckAlive message is used to detect connection losses. It therefore does not have to transport data and can be ignored by the receiver. Accordingly there is no response.

However, if a machine supports the FeatureCheckAliveResponse, it must answer CheckAlive messages with Type set to 1 with a CheckAlive message with Type set to 2 and the same Id as the received CheckAlive message.

Note: The function of CheckAliveResponse is optional. If FeatureCheckAliveResponse is specified in the ServiceDescription, it must be fully supported. Otherwise it can be ignored.

CheckAlive	Type	Range / Multiplicity	Optional	Description
◆ Type	int	1 .. 2	yes	Ping / Pong message type.
◆ Id	string	any string (minimum supported length: 80 bytes)	yes	Identifier of the message.

Type may be one of the following values:

- 1 Ping: CheckAlive request.
- 2 Pong: CheckAlive response.

The machine sending CheckAlive message with Type set to 1 chooses a unique for Id (e.g., GUID or time stamp). The machine responding with CheckAlive message with Type set to 2 has to answer using the same Id.

3.4 ServiceDescription

The ServiceDescription message is sent by both machines after a connection is established. The downstream machine sends its ServiceDescription first whereupon the upstream machine answers by sending its own ServiceDescription.



ServiceDescription	Type	Range / Multiplicity	Optional	Description
◆ Machinelid	string	any string (minimum supported length: 80 bytes)	no	ID / name of the sending machine for identifying it in a Hermes enabled production line.
◆ Lanelid	int	1 .. n	no	The sending machine's lane to which this connection is relating to. Lanes are enumerated looking downstream from right to left beginning with 1.
◆ Interfacelid	string	any string (minimum supported length: 80 bytes)	yes	The ID of the sending machine's transportation interface to which this connection is relating to.
◆ Version	string	xxx.yyy (7 bytes)	no	The implemented interface version of the machine.
📁 SupportedFeatures	Feature []	0 .. n	no	List of supported features (empty for version 1.0).

Feature	Type	Range / Multiplicity	Optional	Description
📁 FeatureCheckAliveResponse	FeatureCheckAliveResponse	1	yes	Indication of CheckAliveResponse function implementation.
📁 FeatureBoardForecast	FeatureBoardForecast	1	yes	In the upstream role: Machine sends BoardForecast messages.
📁 FeatureQueryBoardInfo	FeatureQueryBoardInfo	1	yes	Indication of QueryBoardInfo function implementation.
📁 FeatureSendBoardInfo	FeatureSendBoardInfo	1	yes	Indication of SendBoardInfo function implementation.

xxx.yyy must match the regular expression

`[1-9][0-9]{0,2}\.[0-9]{1,3}`

The features specified in version 1.0 of this protocol have to be provided by any implementation and thus are not listed in the SupportedFeatures list of the ServiceDescription explicitly. The same applies for all mandatory features of the version specified in the Version attribute. All optional features or additional features of a higher version supported by a machine need to be listed in the SupportedFeatures list to indicate their availability.



3.5 Notification

The Notification message is sent by both machines before a connection is terminated (e.g., after protocol errors or before shutdown). It could also be used for general notification purposes.

Notification	Type	Range / Multiplicity	Optional	Description
◆ NotificationCode	int	1 .. n	no	A notification code of the list below. Notification codes above 1000 are not defined by this protocol and may be used by the application.
◆ Severity	int	1 .. 4	no	A value of the list below.
◆ Description	string	any string (minimum supported length: 254 bytes)	no	An English textual description of the notification.

The following NotificationCodes are defined:

- 1 Protocol error (invalid transition in the corresponding state machine)
- 2 Connection refused because of an established connection
- 3 Connection reset because of changed configuration
- 4 Configuration error
- 5 Machine shutdown
- 6 BoardForecast error

Possible values for Severity:

- 1 Fatal error
- 2 Error
- 3 Warning
- 4 Info

3.6 BoardAvailable

The BoardAvailable message is sent to the downstream machine to indicate the readiness of the upstream machine to handover a printed board.

Optional attributes indicate that it is not required to provide them if the information is not available. But if the information is available at the machine, e.g., barcode, then the optional attributes **shall** be set, if not already present there. When an optional attribute is received from an upstream machine, it must be passed on (possibly altered) to the next downstream machine.



BoardAvailable	Type	Range / Multiplicity	Optional	Description
BoardId	string	GUID (36 bytes)	no	Indicating the ID of the available board.
BoardIdCreatedBy	string	non-empty string (minimum supported length: 80 bytes)	no	Machineld of the machine which created the BoardId (the first machine in a consecutive row of machines implementing this protocol). The Machineld is part of the Hermes configuration.
FailedBoard	int	0 .. 2	no	A value of the list below.
ProductTypeId	string	any string (minimum supported length: 254 bytes)	yes	Identifies a collection of printed boards sharing common properties.
FlippedBoard	int	0 .. 2	no	A value of the list below.
TopBarcode	string	any string (minimum supported length: 254 bytes)	yes	The barcode of the top side of the printed board.
BottomBarcode	string	any string (minimum supported length: 254 bytes)	yes	The barcode of the bottom side of the printed board.
Length	float	positive numbers	yes	The length of the printed board in millimeter.
Width	float	positive numbers	yes	The width of the printed board in millimeter.
Thickness	float	positive numbers	yes	The thickness of the printed board in millimeter.
ConveyorSpeed	float	positive numbers	yes	The conveyor speed preferred by the upstream machine in millimeter per second.
TopClearanceHeight	float	positive numbers	yes	The clearance height for the top side of the printed board in millimeter.
BottomClearanceHeight	float	positive numbers	yes	The clearance height for the bottom side of the printed board in millimeter.
Weight	float	positive numbers	yes	The weight of the printed board in grams.



WorkOrderId	string	any string (minimum supported length: 80 bytes)	yes	Identifies the work order for production of the printed board.
-------------	--------	---	-----	--

GUID must match the regular expression

`[0-9a-f]{8}-[0-9a-f]{4}-[0-9a-f]{4}-[0-9a-f]{4}-[0-9a-f]{12}`

FailedBoard may be one of the following values:

- 0 Board of unknown quality available
- 1 Good board available
- 2 Failed board available

FlippedBoard may be one of the following values:

- 0 Side up is unknown
- 1 Board top side is up
- 2 Board bottom side is up

If FlippedBoard is 2 (board bottom side is up) then TopBarcode is facing downwards and BottomBarcode is facing upwards. Same applies for TopClearanceHeight and BottomClearanceHeight.

The definition of board bottom and board top side is outside of the scope of Hermes and is to be determined by the customer.

Figure 23 gives an explanation of TopClearanceHeight and BottomClearanceHeight.

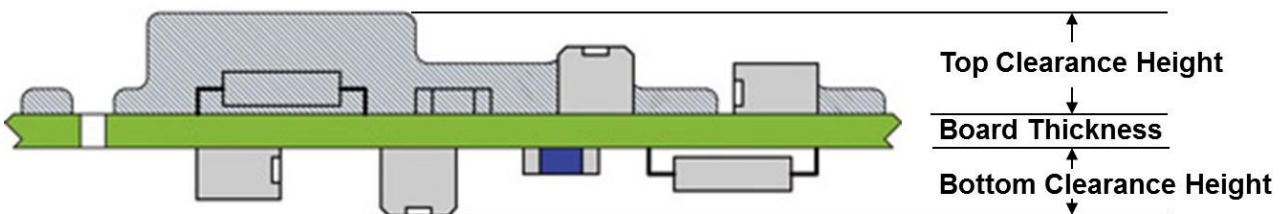

Figure 23 Explanation for Top and Bottom Clearance Height

3.7 RevokeBoardAvailable

With the RevokeBoardAvailable message, the upstream machine signals that it is not ready anymore to handover a printed board.

RevokeBoardAvailable	Type	Range / Multiplicity	Optional	Description
----------------------	------	----------------------	----------	-------------



3.8 MachineReady

The MachineReady message is sent to the upstream machine to indicate the readiness of the downstream machine to accept a printed board.

MachineReady	Type	Range / Multiplicity	Optional	Description
FailedBoard	int	0 .. 2	no	A value of the list below.
ForecastId	string	any string (minimum supported length: 80 bytes)	yes / no	If responding to a BoardForecast message mandatory. It indicates the ID of the original BoardForecast message.
BoardId	string	GUID (36 bytes)	yes	Indicates the ID of the board that will be handed over as next. In case of product change this attribute will not be sent.
ProductTypeId	string	any string (minimum supported length: 254 bytes)	yes	Identifies a collection of printed boards sharing common properties.
FlippedBoard	int	0 .. 2	yes	A value of the list below.
Length	float	positive numbers	yes	The length of the printed board in millimeter.
Width	float	positive numbers	yes	The width of the printed board in millimeter.
Thickness	float	positive numbers	yes	The thickness of the printed board in millimeter.
ConveyorSpeed	float	positive numbers	yes	The conveyor speed used by the upstream machine in millimeter per second.
TopClearanceHeight	float	positive numbers	yes	The clearance height for the top side of the printed board in millimeter.
BottomClearanceHeight	float	positive numbers	yes	The clearance height for the bottom side of the printed board in millimeter.
Weight	float	positive numbers	yes	The weight of the printed board in grams.
WorkOrderId	string	any string (minimum supported length: 80 bytes)	yes	Identifies the work order for production of the printed board.



FlippedBoard may be one of the following values:

- 0 Side up is unknown
- 1 Board top side is up
- 2 Board bottom side is up

FailedBoard may be one of the following values:

- 0 Ready to accept any board
- 1 Ready to accept good boards.
- 2 Ready to accept failed boards

3.9 RevokeMachineReady

With the RevokeMachineReady message, the downstream machine signals that it is not ready anymore to accept a printed board.

RevokeMachineReady	Type	Range / Multiplicity	Optional	Description
--------------------	------	----------------------	----------	-------------

3.10 StartTransport

The StartTransport message is sent to the upstream machine to initiate the printed board handover process. There is no response to this message.

StartTransport	Type	Range / Multiplicity	Optional	Description
BoardId	string	GUID (36 bytes)	no	The ID of the board for which the transport is started.
ConveyorSpeed	float	positive numbers	yes	Optional parameter indicating the selected conveyor speed for the handover in millimeter per second.

The downstream machine is responsible for selecting the actual conveyor speed according to the preferred conveyor speed sent in the BoardAvailable message. In general the highest possible speed supported by both machines will be selected.

If a StartTransport message is received for a BoardId which is not the one received with the last BoardAvailable message, the transport **shall** be canceled. This case is not to be treated as a protocol error.

3.11 StopTransport

The StopTransport message is sent by the downstream machine after it has finished the transport.

StopTransport	Type	Range / Multiplicity	Optional	Description
TransferState	int	1 .. 3	no	A value of the list below.
BoardId	string	GUID (36 bytes)	no	The ID of the board to which the message relates to.



Transfer states:

- 1 NotStarted: The printed board never left and hence is fully inside the upstream machine.
- 2 Incomplete: The transfer was cancelled in progress.
- 3 Complete: The transfer ended successfully.

If the BoardId does not match the one from StartTransport, this **shall** be treated as a protocol error. Therefore, the connection would need to be re-established.

3.12 TransportFinished

The TransportFinished message is sent by the upstream machine after it finished the transport.

TransportFinished	Type	Range / Multiplicity	Optional	Description
◆ TransferState	int	1 .. 3	no	A value of the list below.
◆ BoardId	string	GUID (36 bytes)	no	The ID of the board to which the message relates to.

Transfer states:

- 1 NotStarted: The printed board never left and hence is fully inside the upstream machine.
- 2 Incomplete: The transfer was cancelled in progress.
- 3 Complete: The transfer ended successfully.

If the BoardId does not match the one from StartTransport, this **shall** be treated as a protocol error. Therefore, the connection would need to be re-established.

3.13 BoardForecast

The BoardForecast message is sent to the downstream machine to indicate some changes / command execution are needed or to give advanced information about the next board but a printed board is not yet available. If the ForecastId attribute is set then the downstream machine must at some point respond with a MachineReady carrying the same ForecastId. If needed downstream machine must send a RevokeMachineReady message first. If the forecasted product is not accepted by the downstream machine, then it must respond with a Notification of type "BoardForecastError".

Optional attributes indicate that it is not required to provide them if the information is not available. But if the information is available at the machine, e.g., barcode, then the optional attributes **shall** be set, if not already present there. When an optional attribute is received from an upstream machine, then it must be passed on (possibly altered) to the next downstream machine.

Note: The function of BoardForecast is optional. If FeatureBoardForecast is specified in the ServiceDescription, it must be fully supported. Otherwise it can be ignored.



BoardForecast	Type	Range / Multiplicity	Optional	Description
ForecastId	string	any string (minimum supported length: 80 bytes)	yes	Indicating the ID of forecast message. The ID must be unambiguous and, for example, can be a timestamp or a GUID.
TimeUntilAvailable	float	positive numbers	yes	Number of seconds until a board may be available at downstream machine.
BoardId	string	GUID (36 bytes)	yes	Indicating the ID of the board that will be handed over as next. For example, in case of product change this attribute will not be sent.
BoardIdCreatedBy	string	any string (minimum supported length: 80 bytes)	yes	Machinelid of the machine which created the BoardId.
FailedBoard	int	0 .. 2	no	A value of the list below.
ProductTypeId	string	any string (minimum supported length: 254 bytes)	yes	Identifies a collection of printed boards sharing common properties.
FlippedBoard	int	0 .. 2	no	A value of the list below.
TopBarcode	string	any string (minimum supported length: 254 bytes)	yes	The barcode of the top side of the next printed board.
BottomBarcode	string	any string (minimum supported length: 254 bytes)	yes	The barcode of the bottom side of the next printed board.
Length	float	positive numbers	yes	The length of the printed board in millimeter.
Width	float	positive numbers	yes	The width of the printed board in millimeter.
Thickness	float	positive numbers	yes	The thickness of the printed board in millimeter.
ConveyorSpeed	float	positive numbers	yes	The conveyor speed preferred by the upstream machine in millimeter per second.



◆ TopClearanceHeight	float	positive numbers	yes	The clearance height for the top side of the printed board in millimeter.
◆ BottomClearanceHeight	float	positive numbers	yes	The clearance height for the bottom side of the printed board in millimeter.
◆ Weight	float	positive numbers	yes	The weight of the printed board in grams.
◆ WorkOrderId	string	any string (minimum supported length: 80 bytes)	yes	Identifies the work order for production of the printed board.

The attributes definition are identical to the BoardAvailable message.

FailedBoard may be one of the following values:

- 0 Ready to accept any board
- 1 Ready to accept good boards
- 2 Ready to accept failed boards

FlippedBoard may be one of the following values:

- 0 Side up is unknown
- 1 Board top side is up
- 2 Board bottom side is up

3.14 QueryBoardInfo

The QueryBoardInfo message is sent to the upstream machine to request information about one of the last boards (see 4.1.3).

Note: The function of QueryBoardInfo is optional. If FeatureQueryBoardInfo is specified in the ServiceDescription, it must be fully supported. Otherwise it can be ignored.

QueryBoardInfo	Type	Range / Multiplicity	Optional	Description
◆ TopBarcode	String	any string (minimum supported length: 254 bytes)	yes / no	The barcode of the top side of the printed board. Either top or bottom barcode must be specified.
◆ BottomBarcode	String	any string (minimum supported length: 254 bytes)	yes / no	The barcode of the bottom side of the printed board. Either top or bottom barcode must be specified.



3.15 SendBoardInfo

The SendBoardInfo message is sent to the downstream machine as response of a received QueryBoardInfo message to transfer stored information about one of the last boards (see 4.1.3). If the upstream machine cannot find any board information it will nevertheless send the SendBoardInfo message without the BoardId and BoardCreatedBy attributes.

Machines supporting the feature FeatureSendBoardInfo **shall** be able to store and supply upon request the info of at least the last 50 handled boards.

Optional attributes indicate that it is not required to provide them if the information is not available. But if the information is available at the machine, e.g., barcode, then the optional attributes **shall** be set.

Note: The function of SendBoardInfo is optional. If FeatureSendBoardInfo is specified in the ServiceDescription, it must be fully supported. Otherwise it can be ignored.



SendBoardInfo	Type	Range / Multiplicity	Optional	Description
BoardId	string	GUID (36 bytes)	yes / no	The ID of the board which data has been requested. This attribute will not be sent if the board information has not been found.
BoardIdCreatedBy	string	non-empty string (minimum supported length: 80 bytes)	yes / no	Machineld of the machine which created the BoardId. This attribute will not be sent if the board information has not been found.
FailedBoard	Int	0 .. 2	yes / no	A value of the list below. This attribute will not be sent if the board information has not been found.
ProductTypeId	string	any string (minimum supported length: 254 bytes)	yes	Identifies a collection of printed boards sharing common properties.
FlippedBoard	Int	0 .. 2	yes / no	A value of the list below. This attribute will not be sent if the board information has not been found.
TopBarcode	string	any string (minimum supported length: 254 bytes)	yes / no	The barcode of the top side of the next printed board. This attribute is mandatory if it has been in the QueryBoardInfo message.
BottomBarcode	string	any string (minimum supported length: 254 bytes)	yes / no	The barcode of the bottom side of the next printed board. This attribute is mandatory if it has been in the QueryBoardInfo message.
Length	float	positive numbers	yes	The length of the printed board in millimeter.
Width	float	positive numbers	yes	The width of the printed board in millimeter.
Thickness	float	positive numbers	yes	The thickness of the printed board in millimeter.
TopClearanceHeight	float	positive numbers	yes	The clearance height for the top side of the printed board in millimeter.
BottomClearanceHeight	float	positive numbers	yes	The clearance height for the bottom side of the printed board in millimeter.



◆ WorkOrderId	string	any string (minimum supported length: 80 bytes)	yes	Identifies the work order for production of the printed board.
---------------	--------	--	-----	--

The attributes definition are identical to the BoardAvailable message.

FailedBoard may be one of the following values:

- 0 Board of unknown quality available
- 1 Good board available
- 2 Failed board available

FlippedBoard may be one of the following values:

- 0 Side up is unknown
- 1 Board top side is up
- 2 Board bottom side is up

3.16 SetConfiguration

The SetConfiguration message is sent by an engineering station to configure the Hermes interfaces of a machine. If the sent configuration is not accepted, the machine is expected to send a Notification message (see 3.5).

Note: The function of SetConfiguration is optional on the vertical channel. If FeatureConfiguration is specified in the SupervisoryServiceDescription, it must be fully supported. Otherwise it can be ignored.

SetConfiguration	Type	Range / Multiplicity	Optional	Description
◆ Machineld	string	any string (minimum supported length: 80 bytes)	no	ID / name of this machine for identifying it in a Hermes enabled production line.
◆ SupervisorySystemPort	int	0 .. 65535	yes	Port number on which connections from supervisory systems are established.
▢ UpstreamConfigurations	Upstream Configuration []	0 .. n	no	Configuration for upstream lanes.
▢ DownstreamConfigurations	Downstream Configuration []	0 .. n	no	Configuration for downstream lanes.



UpstreamConfiguration	Type	Range / Multiplicity	Optional	Description
◆ UpstreamLaneId	int	1 .. n	no	The lane on the upstream side. Lanes are enumerated looking downstream from right to left beginning with 1.
◆ UpstreamInterfaceId	string	any string (minimum supported length: 80 bytes)	yes	The ID of the transportation interface on the upstream side.
◆ HostAddress	string	valid IP address or hostname (minimum supported length: 254 bytes)	no	The IP address or hostname of the upstream machine for this lane and transportation interface.
◆ Port	int	0 .. 65535	no	Port number on which connections are established.

DownstreamConfiguration	Type	Range / Multiplicity	Optional	Description
◆ DownstreamLaneId	int	1 .. n	no	The lane on the downstream side. Lanes are enumerated looking downstream from right to left beginning with 1.
◆ DownstreamInterfaceId	string	any string (minimum supported length: 80 bytes)	yes	The ID of the transportation interface on the downstream side.
◆ ClientAddress	string	valid IP address or hostname (minimum supported length: 254 bytes)	yes	The IP address or hostname of the downstream machine for this lane and transportation interface. If not specified, then connections from any IP address are accepted.
◆ Port	int	0 .. 65535	no	Port number on which the server accepts connections for this lane.

All connections where the machine is acting as board provider are stored in DownstreamConfigurations. All connections where the machine is acting as board receiver are stored in UpstreamConfigurations. These are independent of the board transport direction of the SMT line.



It is up to the user to keep Machinelds unique.

3.17 GetConfiguration

The GetConfiguration message is sent by an engineering station to read out the current configuration of the Hermes interfaces of a machine. The machine is expected to answer with a CurrentConfiguration message.

Note: The function of GetConfiguration is optional on the vertical channel. If FeatureConfiguration is specified in the SupervisoryServiceDescription, it must be fully supported. Otherwise it can be ignored.

GetConfiguration	Type	Range / Multiplicity	Optional	Description
------------------	------	----------------------	----------	-------------

3.18 CurrentConfiguration

The CurrentConfiguration message is sent by a machine in response to the GetConfiguration message.

CurrentConfiguration	Type	Range / Multiplicity	Optional	Description
◆ Machineld	string	any string (minimum supported length: 80 bytes)	yes	ID / name of this machine for identifying it in a Hermes enabled production line.
◆ SupervisorySystemPort	int	0 .. 65535	yes	Port number on which connections from supervisory systems are established.
📁 UpstreamConfigurations	Upstream Configuration []	0 .. n	no	Configuration of upstream lanes.
📁 DownstreamConfigurations	Downstream Configuration []	0 .. n	no	Configuration of downstream lanes.

For the definition of UpstreamConfiguration and DownstreamConfiguration see 3.16.

If no Machineld has been configured yet, the CurrentConfiguration message does not contain the attribute Machineld.



3.19 SupervisoryServiceDescription

The SupervisoryServiceDescription message is sent by both machine and supervisory system after a connection is established. The supervisory system sends its SupervisoryServiceDescription first whereupon the machine answers by sending its own SupervisoryServiceDescription.

SupervisoryServiceDescription	Type	Range / Multiplicity	Optional	Description
SystemId	String	any string (minimum supported length: 80 bytes)	no	ID / name of the sending machine or supervisory system for identifying it in a Hermes enabled production line.
Version	String	xxx.yyy (7 bytes)	no	The implemented interface version of the machine or supervisory system.
SupportedFeatures	SupervisoryFeature []	0 .. n	no	List of supported supervisory features (empty for version 1.0).

SupervisoryFeature	Type	Range / Multiplicity	Optional	Description
FeatureConfiguration	FeatureConfiguration	1	yes	Indication of configuration functions implementation.
FeatureCheckAliveResponse	FeatureCheckAliveResponse	1	yes	Indication of CheckAliveResponse function implementation.
FeatureBoardTracking	FeatureBoardTracking	1	yes	Indication of board tracking functions implementation.
FeatureQueryWorkOrderInfo	FeatureQueryWorkOrderInfo	1	yes	Indication of QueryWorkOrderInfo function implementation.
FeatureSendWorkOrderInfo	FeatureSendWorkOrderInfo	1	yes	Indication of SendWorkOrderInfo function implementation.

xxx.yyy must match the regular expression

`[1-9][0-9]{0,2}\.[0-9]{1,3}`

3.20 BoardArrived

The BoardArrived message is sent via Hermes vertical channel to a supervisory system to indicate that a printed board has arrived at this machine. The BoardArrived message **shall** be sent immediately after sending the corresponding StopTransport message.

Optional attributes indicate that it is not required to provide them if the information is not available. But if the information is available at the machine, e.g., barcode, then the optional attributes **shall** be set.





Note: The function of BoardArrived is optional. If FeatureBoardTracking is specified in the SupervisoryServiceDescription, it must be fully supported. Otherwise it can be ignored.



BoardArrived	Type	Range / Multiplicity	Optional	Description
◆ Machinelid	string	any string (minimum supported length: 80 bytes)	no	ID / name of this machine for identifying it in a Hermes enabled production line.
◆ UpstreamLanelid	int	1 .. n	no	The lane on the upstream side. Lanes are enumerated looking downstream from right to left beginning with 1.
◆ UpstreamInterfacelid	string	any string (minimum supported length: 80 bytes)	yes	The ID of the transportation interface on the upstream side.
◆ Magazinelid	string	any string (minimum supported length: 80 bytes)	yes	Barcode of a magazine, required to identify the magazine from which the board was transferred.
◆ Slotid	int	1 .. n	yes	Indicates the slot in the magazine, enumerated from bottom to top, beginning with 1.
◆ BoardTransfer	int	1 .. 3	no	A value of the list below
◆ BoardId	string	GUID (36 bytes)	no	Indicating the ID of the available board
◆ BoardIdCreatedBy	string	non-empty string (minimum supported length: 80 bytes)	no	Machinelid of the machine which created the BoardId (the first machine in a consecutive row of machines implementing this protocol). The Machinelid is part of the Hermes configuration.
◆ FailedBoard	int	0 .. 2	no	A value of the list below.
◆ ProductTypelid	string	any string (minimum supported length: 254 bytes)	yes	Identifies a collection of printed boards sharing common properties.
◆ FlippedBoard	int	0 .. 2	no	A value of the list below.



◆ TopBarcode	string	any string (minimum supported length: 254 bytes)	yes	The barcode of the top side of the printed board.
◆ BottomBarcode	string	any string (minimum supported length: 254 bytes)	yes	The barcode of the bottom side of the printed board.
◆ Length	float	positive numbers	yes	The length of the printed board in millimeter.
◆ Width	float	positive numbers	yes	The width of the printed board in millimeter.
◆ Thickness	float	positive numbers	yes	The thickness of the printed board in millimeter.
◆ ConveyorSpeed	float	positive numbers	yes	The conveyor speed used for the printed board transfer in millimeter per second.
◆ TopClearanceHeight	float	positive numbers	yes	The clearance height for the top side of the printed board in millimeter.
◆ BottomClearanceHeight	float	positive numbers	yes	The clearance height for the bottom side of the printed board in millimeter.
◆ Weight	float	positive numbers	yes	The weight of the printed board in grams.
◆ WorkOrderId	string	any string (minimum supported length: 80 bytes)	yes	Identifies the work order for production of the printed board.

GUID must match the regular expression

`[0-9a-f]{8}-[0-9a-f]{4}-[0-9a-f]{4}-[0-9a-f]{4}-[0-9a-f]{12}`

FailedBoard may be one of the following values:

- 0 Board of unknown quality available
- 1 Good board available
- 2 Failed board available

FlippedBoard may be one of the following values:

- 0 Side up is unknown
- 1 Board top side is up
- 2 Board bottom side is up



BoardTransfer may be one of the following values:

- 1 Transferred: Board arrived from upstream machine via Hermes or SMEMA.
- 2 Loaded: Board was loaded from a magazine or a stack of Boards.
- 3 Inserted: Board was manually inserted into the machine.

3.21 BoardDeparted

The BoardDeparted message is sent via Hermes vertical channel to a supervisory system to indicate that a printed board has left this machine. The BoardDeparted message shall be sent immediately after sending the corresponding TransportFinished message.

Optional attributes indicate that it is not required to provide them if the information is not available. But if the information is available at the machine, e.g., barcode, then the optional attributes **shall** be set.

Note: The function of BoardDeparted is optional. If FeatureBoardTracking is specified in the SupervisoryServiceDescription, it must be fully supported. Otherwise it can be ignored.



BoardDeparted	Type	Range / Multiplicity	Optional	Description
◆ Machinelid	string	any string (minimum supported length: 80 bytes)	no	ID / name of this machine for identifying it in a Hermes enabled production line.
◆ DownstreamLanelid	int	1 .. n	no	The lane on the downstream side. Lanes are enumerated looking downstream from right to left beginning with 1.
◆ DownstreamInterfacelid	string	any string (minimum supported length: 80 bytes)	yes	The ID of the transportation interface on the downstream side.
◆ Magazinelid	string	any string (minimum supported length: 80 bytes)	yes	Barcode of a magazine, required to identify the magazine to which the board was transferred.
◆ Slotid	int	1 .. n	yes	Indicates the slot in the magazine, enumerated from bottom to top, beginning with 1.
◆ BoardTransfer	int	1 .. 3	no	A value of the list below.
◆ BoardId	string	GUID (36 bytes)	no	Indicating the ID of the available board.
◆ BoardIdCreatedBy	string	non-empty string (minimum supported length: 80 bytes)	no	Machinelid of the machine which created the BoardId (the first machine in a consecutive row of machines implementing this protocol). The Machinelid is part of the Hermes configuration.
◆ FailedBoard	int	0 .. 2	no	A value of the list below.
◆ ProductTypelid	string	any string (minimum supported length: 254 bytes)	yes	Identifies a collection of printed boards sharing common properties.
◆ FlippedBoard	int	0 .. 2	no	A value of the list below.



◆ TopBarcode	string	any string (minimum supported length: 254 bytes)	yes	The barcode of the top side of the printed board.
◆ BottomBarcode	string	any string (minimum supported length: 254 bytes)	yes	The barcode of the bottom side of the printed board.
◆ Length	float	positive numbers	yes	The length of the printed board in millimeter.
◆ Width	float	positive numbers	yes	The width of the printed board in millimeter.
◆ Thickness	float	positive numbers	yes	The thickness of the printed board in millimeter.
◆ ConveyorSpeed	float	positive numbers	yes	The conveyor speed used for the printed board transfer in millimeter per second.
◆ TopClearanceHeight	float	positive numbers	yes	The clearance height for the top side of the printed board in millimeter.
◆ BottomClearanceHeight	float	positive numbers	yes	The clearance height for the bottom side of the printed board in millimeter.
◆ Weight	float	positive numbers	yes	The weight of the printed board in grams.
◆ WorkOrderId	string	any string (minimum supported length: 80 bytes)	yes	Identifies the work order for production of the printed board.

GUID must match the regular expression

`[0-9a-f]{8}-[0-9a-f]{4}-[0-9a-f]{4}-[0-9a-f]{4}-[0-9a-f]{12}`

FailedBoard may be one of the following values:

- 0 Board of unknown quality available
- 1 Good board available
- 2 Failed board available

FlippedBoard may be one of the following values:

- 0 Side up is unknown
- 1 Board top side is up
- 2 Board bottom side is up



BoardTransfer may be one of the following values:

- 1 Transferred: Board moved to downstream machine via Hermes or SMEMA.
- 2 Unloaded: Board was unloaded into a magazine.
- 3 Removed: Board was manually taken out of the machine.

3.22 QueryWorkOrderInfo

The QueryWorkOrderInfo message is sent via Hermes vertical channel from a machine to a supervisory system to query the work order and initial board data for a printed board or a set of printed boards. Three scenarios are covered:

- 1) Printed boards arrive within a magazine
- 2) A stack of printed boards arrives
- 3) A printed board is inserted and its barcode is known

Note: The function of QueryWorkOrderInfo is optional. If FeatureQueryWorkOrderInfo is specified in the SupervisoryServiceDescription, it must be fully supported. Otherwise it can be ignored.

QueryWorkOrderInfo	Type	Range / Multiplicity	Optional	Description
◆ QueryId	string	any string (minimum supported length: 80 bytes)	yes	Indicates the ID of QueryWorkOrder message. The ID must be unambiguous and for example can be a timestamp or a GUID.
◆ MachineId	string	any string (minimum supported length: 80 bytes)	no	ID / name of this machine for identifying it in a Hermes enabled production line.
◆ MagazineId	string	any string (minimum supported length: 80 bytes)	yes	Barcode of a magazine, required to identify the magazine.
◆ SlotId	int	1 .. n	yes	Indicates the slot in the magazine, enumerated from bottom to top, beginning with 1.
◆ Barcode	string	any string (minimum supported length: 254 bytes)	yes	The barcode of the printed board.

GUID must match the regular expression

`[0-9a-f]{8}-[0-9a-f]{4}-[0-9a-f]{4}-[0-9a-f]{4}-[0-9a-f]{12}`



3.23 SendWorkOrderInfo

The SendWorkOrderInfo message is sent via Hermes vertical channel from a supervisory system to a machine to provide the work order and the initial board data for a printed board or a set of printed boards. If the supervisory system cannot find any work order information it will nevertheless send the SendWorkOrderInfo message without any attributes except QueryId, if provided upon request.

Optional attributes indicate that it is not required to provide them if the information is not available. But if the information is available at the supervisory system, e.g., barcode, then the optional attributes **shall** be set.

Note: The function of SendWorkOrderInfo is optional. If FeatureSendWorkOrderInfo is specified in the SupervisoryServiceDescription, it must be fully supported. Otherwise it can be ignored.



SendWorkOrderInfo	Type	Range / Multiplicity	Optional	Description
◆ QueryId	string	any string (minimum supported length: 80 bytes)	yes / no	ID of QueryWorkOrderInfo this message refers to. This attribute is mandatory if it has been in the QueryWorkOrderInfo message.
◆ WorkOrderId	string	non-empty string (minimum supported length: 80 bytes)	yes	Identifies the work order for production of the printed board.
◆ BoardId	string	GUID (36 bytes)	yes	Indicating the ID of the available board.
◆ BoardIdCreatedBy	string	non-empty string (minimum supported length: 80 bytes)	yes	Machineld of the machine which created the BoardId (the first machine in a consecutive row of machines implementing this protocol). The Machineld is part of the Hermes configuration.
◆ FailedBoard	int	0 .. 2	yes / no	A value of the list below. This attribute will not be sent if the board information has not been found.
◆ ProductTypeId	string	any string (minimum supported length: 254 bytes)	yes	Identifies a collection of printed boards sharing common properties.
◆ FlippedBoard	int	0 .. 2	yes / no	A value of the list below. This attribute will not be sent if the board information has not been found.
◆ TopBarcode	string	any string (minimum supported length: 254 bytes)	yes / no	The barcode of the top side of the printed board. This attribute is mandatory if it has been the barcode in the QueryWorkOrderInfo message.
◆ BottomBarcode	string	any string (minimum supported length: 254 bytes)	yes / no	The barcode of the bottom side of the printed board. This attribute is mandatory if it has been the barcode in the QueryWorkOrderInfo message.
◆ Length	float	positive numbers	yes	The length of the printed board in millimeter.



Width	float	positive numbers	yes	The width of the printed board in millimeter.
Thickness	float	positive numbers	yes	The thickness of the printed board in millimeter.
ConveyorSpeed	float	positive numbers	yes	The conveyor speed used for the printed board transfer in millimeter per second.
TopClearanceHeight	float	positive numbers	yes	The clearance height for the top side of the printed board in millimeter.
BottomClearanceHeight	float	positive numbers	yes	The clearance height for the bottom side of the printed board in millimeter.
Weight	float	positive numbers	yes	The weight of the printed board in grams.

GUID must match the regular expression

`[0-9a-f]{8}-[0-9a-f]{4}-[0-9a-f]{4}-[0-9a-f]{4}-[0-9a-f]{12}`

FailedBoard may be one of the following values:

- 0 Board of unknown quality available
- 1 Good board available
- 2 Failed board available

FlippedBoard may be one of the following values:

- 0 Side up is unknown
- 1 Board top side is up
- 2 Board bottom side is up



4 Appendix

4.1 Special Scenarios

The following sections are not part of the Hermes protocol specification. In fact they show the application of this protocol in some special scenarios.

4.1.1 Board Tracking When Board Is Torn Out From the Line

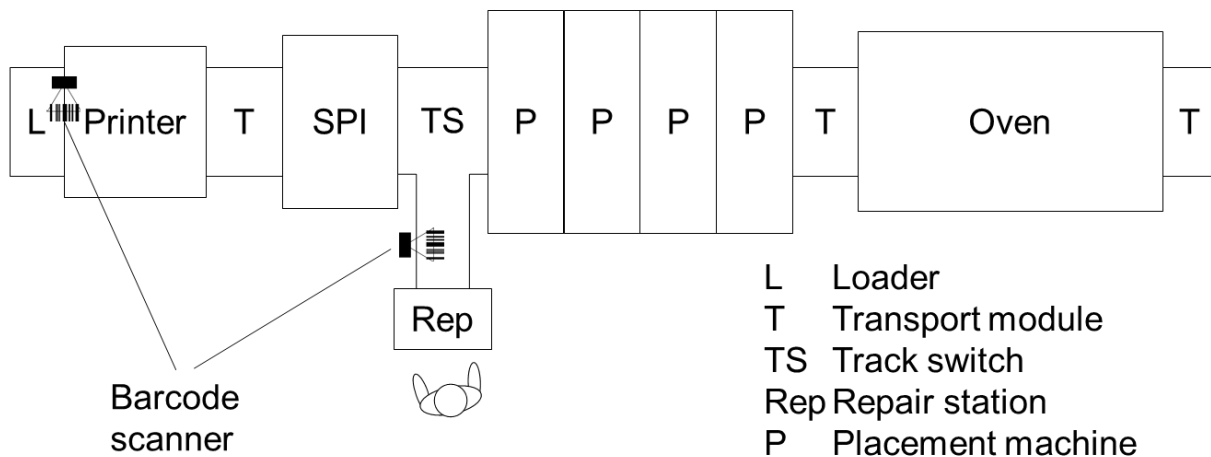

Figure 24 Line Setup with Barcode Readers and Repair Station

In this scenario (shown in Figure 24), a repair station is placed behind the solder paste inspection (SPI). Printed boards failing the solder paste inspection are torn out by the track switch and are presented to an operator at the repair station. The operator may take out the printed board for rework and reinsert it later independent of the printed board sequence.

By removing the printed board from the line, the link between the printed board and the barcode respectively the BoardId is lost. So when the printed board is reinserted, different approaches are possible to re-establish the tracking of the printed board:

- Create a new Hermes BoardId, read the barcode and report the from now on used tracking information. The tracking information can be merged later by an external system (e.g., manufacturing execution system (MES)) using the barcodes.
- Read the barcode first and request the corresponding Hermes BoardId from the external system (e.g., MES). The tracking can be continued using the primarily assigned Hermes BoardId.
- The machine blocks the production of the reinserted printed board until the operator scans the barcode using a mobile barcode scanner or enters it manually and specifies which board side is currently up. Then the original Hermes BoardId and all the needed information is requested from the upstream machine via the QueryBoardInfo message. The downstream machine sends the QueryBoardInfo with the top or bottom barcode and gets back a SendBoardInfo message from the upstream machine including BoardId. If information for that barcode was not available, the attribute BoardId will be omitted.



- d) Simplest but most unsecure approach: The repair station prompts the operator to confirm that the inserted printed board is the same which was last removed from the station.

Option a and b are realized with an MES system. Option c and d enables the reinsertion of boards directly at the machine without having an MES system for that line (relying only on functions of Hermes).

4.1.2 Board Tracking When Board Is Temporarily Removed From the Line

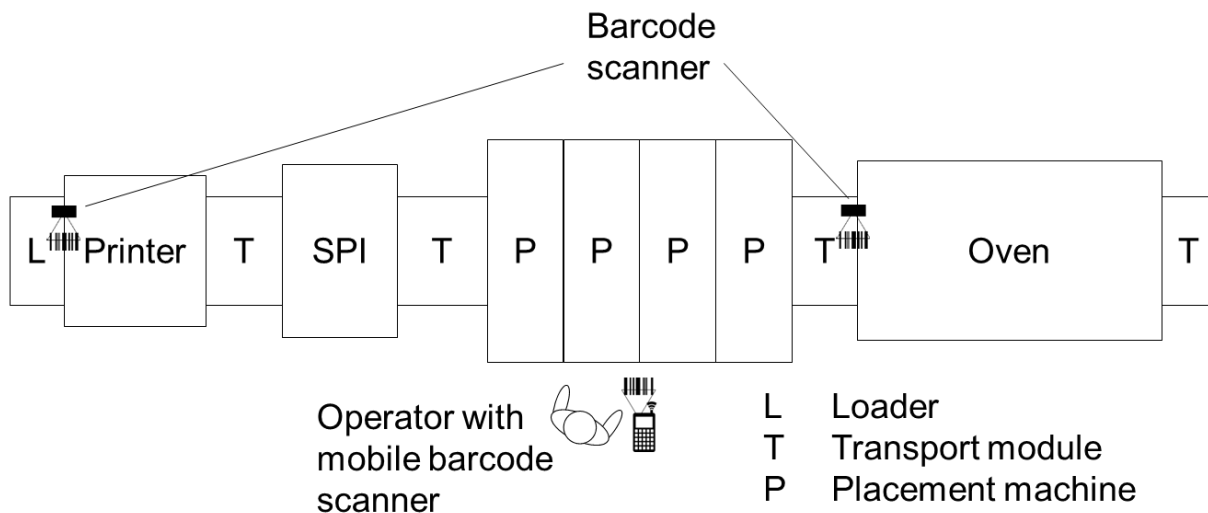

Figure 25 Line Setup with Fixed and Mobile Barcode Readers

In this scenario (shown in Figure 25), the operator removes a printed board for inspection from one of the placement machines. The line continues producing printed boards. At some later point in time, the printed board is reinserted to complete its production.

By removing the printed board from the line, the link between the printed board and the barcode respectively the BoardId is lost. As in the scenario above, different approaches are possible to re-establish the tracking of the printed board:

- a) The machine blocks the production of the reinserted printed board until the operator scans the barcode using a mobile barcode scanner or enters it manually. Then either the original Hermes BoardId is requested from an external system (e.g., MES) using the barcode or a new Hermes BoardId is created and the tracking information is merged by the external system.
- b) The machine blocks the production of the reinserted printed board until the operator scans the barcode using a mobile barcode scanner or enters it manually and specifies which board side is currently up. Then the original Hermes BoardId and all the needed information is requested from the upstream machine via the QueryBoardInfo message. The downstream machine sends the QueryBoardInfo with the top or bottom barcode and gets back a SendBoardInfo message from the upstream machine including BoardId. If information for that barcode was not available, the attribute BoardId will be omitted.
- c) A new Hermes BoardId is created and production is continued without barcode. At the next barcode reader in the line, the barcode information is complemented to the Hermes BoardId. An external system can later merge all the collected tracking information.



Option a and c are realized with an MES system. Option b enables the reinsertion of boards directly at the machine without having an MES system for that line (relying only on functions of Hermes).

4.1.3 Board Tracking When Board was Transferred Without Data

In this scenario scenario, based on a line configuration as shown in Figure 25, one of the machines (e.g., a soldering reflow machine) cannot physically stop the transport of the printed board at the end of the machine. Because of this, boards may pile up if the next machine is not able to process the boards.

In that case the operator will temporarily remove the boards from the line and try to reinsert those at the same place a bit later on.

By removing a printed board from the line, the link between the printed board, the BoardId and other information (width, length, etc.) is lost. As in the scenario above, different approaches are possible to re-establish the tracking of the printed board:

- a) The machine blocks the production of the reinserted printed board until the operator scans the barcode using a mobile barcode scanner or enters it manually. Then either the original Hermes BoardId is requested from an external system (e.g., MES) using the barcode or a new Hermes BoardId is created and the tracking information is merged by the external system.
- b) The machine blocks the production of the reinserted printed board until the operator scans the barcode using a mobile barcode scanner or enters it manually and specifies which board side is currently up. Then the original Hermes BoardId and all the needed information is requested from the upstream machine, that could not stop the printed board, via the QueryBoardInfo message. The downstream machine sends the QueryBoardInfo with the top or bottom barcode and gets back a SendBoardInfo message from the upstream machine including BoardId. If information for that barcode was not available then the attribute BoardId will be omitted.
- c) A new Hermes BoardId is created and production is continued without barcode. Information will not be available for the next machine. At the next barcode reader in the line, the barcode information is added to the Hermes data. An external system can later merge all the collected tracking information (if needed).

Option a and c are realized with an MES system. Option b enables the reinsertion of boards directly at the next machine without having an MES system for that line (relying only on functions of Hermes).



4.2 Glossary / Abbreviations

AOI	Automatic Optical Inspection
GUID	Globally Unique Identifier
ID	Identifier
IP	Internet Protocol
ISO / OSI	International Organization for Standardization / Open System Interconnection
M2M	Machine-to-Machine
MES	Manufacturing Execution System
SMEMA	Surface Mount Equipment Manufacturers Association
SMT	Surface-Mount Technology
SPI	Solder Paste Inspection
TCP	Transmission Control Protocol
XML	Extensible Markup Language

4.3 References

[IPC_SMEMA_9851]	IPC-SMEMA-9851 Mechanical Equipment Interface Standard
[ISO_7498-1]	ISO/IEC IS 7498-1: Information technology – Open Systems Interconnection – Basic Reference Model: The Basic Model. 1996
[IETF_RFC_791]	Internet Engineering Task Force: RFC791: Internet Protocol. September 1981
[IETF_RFC_2460]	Internet Engineering Task Force: RFC791: Internet Protocol, Version 6 (IPv6). September 1998
[IETF_RFC_793]	Internet Engineering Task Force: RFC793: Transmission Control Protocol. September 1981
[ITU-T_REC_X.667]	International Standard "Generation and registration of Universally Unique Identifiers (UUIDs) and their use as ASN.1 Object Identifier components
[SemVer_2.0.0]	Tom Preston-Werner: Semantic Versioning 2.0.0. (Internet: https://semver.org/spec/v2.0.0.html , last access: 23. April 2018)
[W3C_XML_1.1]	Extensible Markup Language (XML) 1.1 (Second Edition) - W3C Recommendation 16. August 2006, edited in place 29. September 2006
[W3C_DATE_TIME]	Date and Time Formats - W3C Recommendation 15. September 1997
[W3C_XML_Schema]	XML Schema Part 2: Datatypes Second Edition - W3C Recommendation 28. October 2004



4.4 History

Version	Date	Author	Change
1.0	03/23/17	The Hermes Standard Initiative	Initial Version
1.0.1	11/13/17	The Hermes Standard Initiative	Incorporation of changes agreed in initiative meeting <ul style="list-style-type: none"> • Add Top and Bottom clearance height attribute to Board Available message • When already connected to a downstream machine, reject new connection attempts • Specify the BoardId to be a true globally unique identifier (GUID / UUID) • Remove BoardIdCreatedBy from StartTransport, StopTransport, TransportFinished
1.0.2	04/23/18	The Hermes Standard Initiative	Incorporation of changes agreed in initiative meeting <ul style="list-style-type: none"> • Application of Semantic Versioning • Define minimum requirements for strings
1.1	04/23/18	The Hermes Standard Initiative	Incorporation of changes agreed in initiative meeting <ul style="list-style-type: none"> • Adding Interfaceld to the configuration • Add weight attribute to BoardAvailable message • CheckAlive Response • BoardForecast • Reinsert Board
1.2	01/28/19	The Hermes Standard Initiative	Incorporation of changes agreed in initiative meeting <ul style="list-style-type: none"> • Clarification of version number and supported features • Add WorkOrderID to related messages • Foundation of vertical channel • Board tracking to supervisory system • Work order handling
1.2.1	11/11/19	The Hermes Standard Initiative	Incorporation of changes agreed in initiative meeting <ul style="list-style-type: none"> • Further clarification of the meaning of "optional" for attributes

